

## ***CC1100 Single Chip Low Cost Low Power RF-Transceiver***

### **Applications**

- Ultra low power UHF wireless transceivers
- 315/433/868 and 915MHz ISM/SRD band systems
- AMR – Automatic Meter Reading
- Consumer Electronics
- RKE – Two-way Remote Keyless Entry

- Low power telemetry
- Home and building automation
- Wireless alarm and security systems
- Industrial monitoring and control
- Wireless sensor networks

### **Product Description**

The **CC1100** is a low cost true single chip UHF transceiver designed for very low power wireless applications. The circuit is mainly intended for the ISM (Industrial, Scientific and Medical) and SRD (Short Range Device) frequency bands at 315, 433, 868 and 915MHz, but can easily be programmed for operation at other frequencies in the 300-348MHz, 400-464MHz and 800-928MHz bands.

The RF transceiver is integrated with a highly configurable baseband modem. The modem supports various modulation formats and has a configurable data rate up to 500kbps. Performance can be increased by enabling a Forward Error Correction option, which is integrated in the modem.

**CC1100** provides extensive hardware support for packet handling, data buffering, burst transmissions, clear channel assessment, link quality indication and wake on radio.

The main operating parameters and the 64-byte transmit/receive FIFOs of **CC1100** can be controlled via an SPI interface. In a typical system, the **CC1100** will be used together with a

microcontroller and a few additional passive components.

**CC1100** is based on Chipcon's SmartRF®04 technology in 0.18µm CMOS.

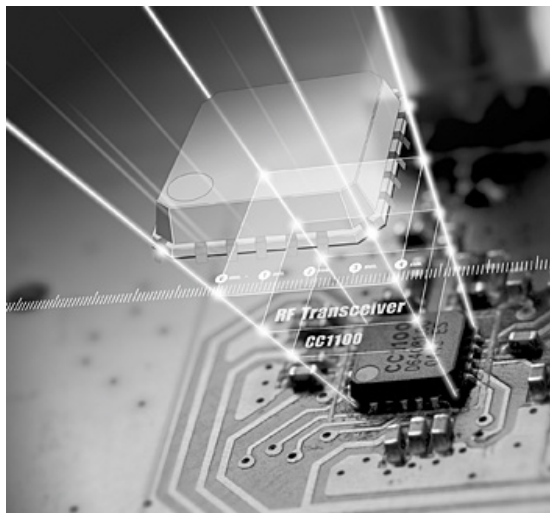

### **Key Features**

- Small size (QLP 4x4mm package, 20 pins)
- True single chip UHF RF transceiver
- Frequency bands: 300-348MHz, 400-464MHz and 800-928MHz
- High sensitivity (-110dBm at 1.2kbps, 1% packet error rate)
- Programmable data rate up to 500kbps
- Low current consumption (15.6mA in RX, 2.4kbps, 433MHz)
- Programmable output power up to +10dBm for all supported frequencies
- Excellent receiver selectivity and blocking performance

- Very few external components: Totally on-chip frequency synthesizer, no external filters or RF switch needed
- Programmable baseband modem
- Ideal for multi-channel operation
- Configurable packet handling hardware
- Suitable for frequency hopping systems due to a fast settling frequency synthesizer
- Optional Forward Error Correction with interleaving
- Separate 64-byte RX and TX data FIFOs
- Efficient SPI interface: All registers can be programmed with one "burst" transfer

## Features (continued from front page)

- Digital RSSI output
  - Suited for systems compliant with EN 300 220 (Europe) and FCC CFR Part 15 (US)
  - Wake-on-radio functionality for automatic low-power RX polling
  - Many powerful digital features allow a high-performance RF system to be made using an inexpensive microcontroller
  - Integrated analog temperature sensor
  - Lead-free “green” package
  - Flexible support for packet oriented systems: On chip support for sync word detection, address check, flexible packet length and automatic CRC handling.
  - Programmable channel filter bandwidth
  - OOK and flexible ASK shaping supported
  - 2-FSK, GFSK and MSK supported.
  - Automatic Frequency Compensation can be used to align the frequency synthesizer to the received centre frequency
- Optional automatic whitening and de-whitening of data
  - Support for asynchronous transparent receive/transmit mode for backwards compatibility with existing radio communication protocols
  - Programmable Carrier Sense indicator
  - Programmable Preamble Quality Indicator for detecting preambles and improved protection against sync word detection in random noise
  - Support for automatic Clear Channel Assessment (CCA) before transmitting (for listen-before-talk systems)
  - Support for per-package Link Quality Indication

## Abbreviations

Abbreviations used in this data sheet are described below.

2-FSK	Binary Frequency Shift Keying	MSK	Minimum Shift Keying
ADC	Analog to Digital Converter	PA	Power Amplifier
AFC	Automatic Frequency Offset Compensation	PCB	Printed Circuit Board
AGC	Automatic Gain Control	PD	Power Down
AMR	Automatic Meter Reading	PER	Packet Error Rate
ASK	Amplitude Shift Keying	PLL	Phase Locked Loop
BER	Bit Error Rate	PQI	Preamble Quality Indicator
CCA	Clear Channel Assessment	PQT	Preamble Quality Threshold
CRC	Cyclic Redundancy Check	RCOSC	RC Oscillator
CS	Carrier Sense	RF	Radio Frequency
DC	Direct Current	RSSI	Received Signal Strength Indicator
EIRP	Equivalent Isotropic Radiated Power	RX	Receive, Receive Mode
ESR	Equivalent Series Resistance	SAW	Surface Acoustic Wave
FEC	Forward Error Correction	SNR	Signal to Noise Ratio
FIFO	First-In-First-Out	SPI	Serial Peripheral Interface
FSK	Frequency Shift Keying	TBD	To Be Defined
GFSK	Gaussian shaped Frequency Shift Keying	TX	Transmit, Transmit Mode
IF	Intermediate Frequency	VCO	Voltage Controlled Oscillator
LBT	Listen Before Transmit	WOR	Wake on Radio, Low power polling
LNA	Low Noise Amplifier	XOSC	Crystal Oscillator
LO	Local Oscillator	XTAL	Crystal
LQI	Link Quality Indicator		
MCU	Microcontroller Unit		

## Table Of Contents

1	ABSOLUTE MAXIMUM RATINGS.....	5
2	OPERATING CONDITIONS.....	5
3	ELECTRICAL SPECIFICATIONS.....	6
4	GENERAL CHARACTERISTICS .....	7
5	RF RECEIVE SECTION.....	8
6	RF TRANSMIT SECTION.....	9
7	CRYSTAL OSCILLATOR.....	9
8	LOW POWER RC OSCILLATOR.....	10
9	FREQUENCY SYNTHESIZER CHARACTERISTICS.....	10
10	ANALOG TEMPERATURE SENSOR.....	11
11	DC CHARACTERISTICS .....	11
12	POWER ON RESET.....	12
13	PIN CONFIGURATION .....	12
14	CIRCUIT DESCRIPTION.....	14
15	APPLICATION CIRCUIT.....	14
16	CONFIGURATION OVERVIEW .....	16
17	CONFIGURATION SOFTWARE .....	17
18	4-WIRE SERIAL CONFIGURATION AND DATA INTERFACE .....	18
18.1	CHIP STATUS BYTE .....	18
18.2	REGISTER ACCESS.....	19
18.3	COMMAND STROBES .....	19
18.4	FIFO ACCESS.....	19
18.5	PATABLE ACCESS.....	19
19	MICROCONTROLLER INTERFACE AND PIN CONFIGURATION .....	21
19.1	CONFIGURATION INTERFACE.....	21
19.2	GENERAL CONTROL AND STATUS PINS .....	21
19.3	OPTIONAL RADIO CONTROL FEATURE.....	22
20	DATA RATE PROGRAMMING.....	22
21	RECEIVER CHANNEL FILTER BANDWIDTH.....	22
22	DEMODULATOR, SYMBOL SYNCHRONIZER AND DATA DECISION.....	23
22.1	FREQUENCY OFFSET COMPENSATION.....	23
22.2	BIT SYNCHRONIZATION.....	23
22.3	BYTE SYNCHRONIZATION .....	23
23	PACKET HANDLING HARDWARE SUPPORT .....	24
23.1	DATA WHITENING.....	24
23.2	PACKET FORMAT .....	24
23.3	PACKET FILTERING IN RECEIVE MODE .....	26
23.4	PACKET HANDLING IN TRANSMIT MODE.....	26
23.5	PACKET HANDLING IN RECEIVE MODE .....	26
24	MODULATION FORMATS.....	27
24.1	FREQUENCY SHIFT KEYING.....	27
24.2	MINIMUM SHIFT KEYING.....	27
24.3	AMPLITUDE MODULATION .....	27
25	RECEIVED SIGNAL QUALIFIERS AND LINK QUALITY INFORMATION .....	27
25.1	PREAMBLE QUALITY THRESHOLD (PQT) .....	27
25.2	RSSI.....	28
25.3	CARRIER SENSE (CS).....	28
25.4	CLEAR CHANNEL ASSESSMENT (CCA) .....	28
25.5	LINK QUALITY INDICATOR (LQI).....	28
26	FORWARD ERROR CORRECTION WITH INTERLEAVING.....	28
26.1	FORWARD ERROR CORRECTION (FEC).....	29
26.2	INTERLEAVING .....	29
27	RADIO CONTROL .....	30
27.1	POWER ON START-UP SEQUENCE.....	31
27.2	CRYSTAL CONTROL.....	31

27.3	VOLTAGE REGULATOR CONTROL.....	31
27.4	ACTIVE MODES .....	31
27.5	WAKE ON RADIO (WOR) .....	32
27.6	TIMING .....	33
27.7	RX TERMINATION TIMER .....	33
28	DATA FIFO .....	34
29	FREQUENCY PROGRAMMING .....	35
30	VCO.....	35
30.1	VCO AND PLL SELF-CALIBRATION .....	35
31	VOLTAGE REGULATORS .....	35
32	OUTPUT POWER PROGRAMMING .....	36
33	CRYSTAL OSCILLATOR.....	37
34	ANTENNA INTERFACE.....	38
35	GENERAL PURPOSE / TEST OUTPUT CONTROL PINS .....	38
36	ASYNCHRONOUS AND SYNCHRONOUS SERIAL OPERATION .....	40
36.1	ASYNCHRONOUS OPERATION.....	40
36.2	SYNCHRONOUS SERIAL OPERATION .....	40
37	CONFIGURATION REGISTERS .....	40
37.1	CONFIGURATION REGISTER DETAILS – REGISTERS WITH PRESERVED VALUES IN SLEEP STATE .....	45
37.2	CONFIGURATION REGISTER DETAILS – REGISTERS THAT LOOSE PROGRAMMING IN SLEEP STATE .....	59
37.3	STATUS REGISTER DETAILS.....	60
38	PACKAGE DESCRIPTION (QLP 20).....	63
38.1	RECOMMENDED PCB LAYOUT FOR PACKAGE (QLP 20).....	64
38.2	PACKAGE THERMAL PROPERTIES .....	64
38.3	SOLDERING INFORMATION.....	64
38.4	TRAY SPECIFICATION.....	65
38.5	CARRIER TAPE AND REEL SPECIFICATION .....	65
39	ORDERING INFORMATION .....	65
40	GENERAL INFORMATION .....	66
40.1	DOCUMENT HISTORY .....	66
40.2	PRODUCT STATUS DEFINITIONS .....	66
40.3	DISCLAIMER .....	66
40.4	TRADEMARKS.....	66
40.5	LIFE SUPPORT POLICY .....	66
41	ADDRESS INFORMATION.....	68

## 1 Absolute Maximum Ratings

Under no circumstances must the absolute maximum ratings given in Table 1 be violated. Stress exceeding one or more of the limiting values may cause permanent damage to the device.

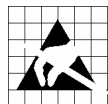

**Caution!** ESD sensitive device.  
Precaution should be used when handling the device in order to prevent permanent damage.

Parameter	Min	Max	Units	Condition
Supply voltage	-0.3	3.6	V	All supply pins must have the same voltage
Voltage on any digital pin	-0.3	VDD+0.3, max 3.6	V	
Voltage on the pins RF_P, RF_N and DCOUPL	-0.3	2.0	V	
Input RF level		10	dBm	
Storage temperature range	-50	150	°C	
Solder reflow temperature		265	°C	According to IPC/JEDEC J-STD-020C

**Table 1: Absolute Maximum Ratings**

## 2 Operating Conditions

The operating conditions for **CC1100** are listed Table 2 in below.

Parameter	Min	Max	Unit	Condition
Operating temperature	-40	85	°C	
Operating supply voltage	1.8	3.6	V	All supply pins must have the same voltage

**Table 2: Operating Conditions**

### 3 Electrical Specifications

T<sub>c</sub> = 25°C, VDD = 3.0V if nothing else stated. Measured on Chipcon's CC1100EM reference design.

Parameter	Min	Typ	Max	Unit	Condition
Current consumption in power down modes		900		nA	Voltage regulator to digital part off, register values retained, low-power RC oscillator running (SLEEP state with WOR enabled)
		400		nA	Voltage regulator to digital part off, register values retained (SLEEP state)
		90		μA	Voltage regulator to digital part off, register values retained, XOSC running (SLEEP state with <code>MCSM0.OSC_FORCE_ON</code> set)
		160		μA	Voltage regulator to digital part on, all other modules in power down (XOFF state)
Current consumption		15		μA	Automatic RX polling once each second, using low-power RC oscillator, with 460kHz filter bandwidth and 250kbps data rate, PLL calibration every 4 <sup>th</sup> wakeup. Average current with signal in channel <i>below</i> carrier sense level.
		34		μA	Same as above, but with signal in channel <i>above</i> carrier sense level, 1.9ms RX timeout, and no preamble/sync word found.
		1.8		μA	Automatic RX polling every 15 <sup>th</sup> second, using low-power RC oscillator, with 460kHz filter bandwidth and 250kbps data rate, PLL calibration every 4 <sup>th</sup> wakeup. Average current with signal in channel below carrier sense level.
		15		μA	Same as above, but with signal in channel <i>above</i> carrier sense level, 14ms RX timeout, and no preamble/sync word found.
		1.9		mA	Only voltage regulator to digital part and crystal oscillator running (IDLE state)
		8.7		mA	Only the frequency synthesizer running (after going from IDLE until reaching RX or TX states, and frequency calibration states)
Current consumption, 315MHz		26.9		mA	Transmit mode, +10dBm output power
		18.3			Transmit mode, 5dBm output power
		15.1			Transmit mode, 0dBm output power
		13.4			Transmit mode, -10dBm output power
		15.1			Receive mode, 2.4kbps, input at sensitivity limit
		14.0			Receive mode, 2.4kbps, input 30dB above sensitivity limit
		16.2			Receive mode, 250kbps, input at sensitivity limit
		15.1			Receive mode, 250kbps, input 30dB above sensitivity limit
Current consumption, 433MHz		28.8		mA	Transmit mode, +10dBm output power
		19.3			Transmit mode, 5dBm output power
		16.1			Transmit mode, 0dBm output power
		14.3			Transmit mode, -10dBm output power
		15.6			Receive mode, 2.4kbps, input at sensitivity limit
		14.5			Receive mode, 2.4kbps, input 30dB above sensitivity limit
		16.5			Receive mode, 250kbps, input at sensitivity limit
		15.5			Receive mode, 250kbps, input 30dB above sensitivity limit

Parameter	Min	Typ	Max	Unit	Condition
Current consumption, 868/915MHz		30.3		mA	Transmit mode, +10dBm output power
		19.7			Transmit mode, 5dBm output power
		16.6			Transmit mode, 0dBm output power
		14.0			Transmit mode, -10dBm output power
		15.4			Receive mode, 2.4kbps, input at sensitivity limit
		14.2			Receive mode, 2.4kbps, input 30dB above sensitivity limit
		16.2			Receive mode, 250kbps, input at sensitivity limit
		15.2			Receive mode, 250kbps, input 30dB above sensitivity limit

**Table 3: Electrical Specifications**

#### 4 General Characteristics

Parameter	Min	Typ	Max	Unit	Condition/Note
Frequency range	300		348	MHz	
	400		464	MHz	
	800		928	MHz	
Data rate	1.2		500	kbps	Modulation formats supported: (Shaped) MSK (also known as differential offset QPSK) up to 500kbps 2-FSK up to 500kbps GFSK and OOK/ASK (up to 250kbps) Optional Manchester encoding (halves the data rate).

**Table 4: General Characteristics**

## 5 RF Receive Section

T<sub>c</sub> = 25°C, VDD = 3.0V if nothing else stated. Measured on Chipcon's CC1100EM reference design.

Parameter	Min	Typ	Max	Unit	Condition/Note
Differential input impedance		TBD		Ω	Follow CC1100EM reference design
Receiver sensitivity 315/433/868/915MHz		-110		dBm	2-FSK, 1.2kbps, 5.2kHz deviation, 1% packet error rate, 62 bytes packet length, 58kHz digital channel filter bandwidth
		-100		dBm	2-FSK, 38.4kbps, 20kHz deviation, 1% packet error rate, 62 bytes packet length, 100kHz digital channel filter bandwidth
		-88		dBm	2-FSK, 250kbps, 127kHz deviation, 1% packet error rate, 62 bytes packet length, 540kHz digital channel filter bandwidth
		-88		dBm	OOK, 250kbps OOK, 1% packet error rate, 62 bytes packet length, 540kHz digital channel filter bandwidth
Saturation		-15		dBm	
Digital channel filter bandwidth	58		650	kHz	User programmable. The bandwidth limits are proportional to crystal frequency (given values assume a 26.0MHz crystal).
Adjacent channel rejection, 868MHz		23		dB	2-FSK, 38.4kbps, 20kHz deviation, 1% packet error rate, 62 bytes packet length, 100kHz digital channel filter, 150kHz channel spacing  Desired channel 3dB above the sensitivity limit.
Alternate channel rejection, 868MHz		33		dB	2-FSK, 38.4kbps, 20kHz deviation, 1% packet error rate, 62 bytes packet length, 100kHz digital channel filter, 150kHz channel spacing  Desired channel 3dB above the sensitivity limit.
Image channel rejection, 868MHz		29		dB	2-FSK, 38.4kbps, 20kHz deviation, 1% packet error rate, 62 bytes packet length, 100kHz digital channel filter, 150kHz channel spacing, IF frequency 305kHz  Desired channel 3dB above the sensitivity limit.
Blocking at 1MHz offset, 868MHz		52		dB	Desired channel 3dB above the sensitivity limit. Compliant to ETSI EN 300 220 class 2 receiver requirement.
Blocking at 2MHz offset, 868MHz		54		dB	Desired channel 3dB above the sensitivity limit. Compliant to ETSI EN 300 220 class 2 receiver requirement.
Blocking at 5MHz offset, 868MHz		61		dB	Desired channel 3dB above the sensitivity limit. Compliant to ETSI EN 300 220 class 2 receiver requirement.
Blocking at 10MHz offset, 868MHz		64		dB	Desired channel 3dB above the sensitivity limit. Compliant to ETSI EN 300 220 class 2 receiver requirement.
Spurious emissions			-57	dBm	25MHz – 1GHz
			-47	dBm	Above 1GHz

**Table 5: RF Receive Section**



## 6 RF Transmit Section

Tc = 25°C, VDD = 3.0V, +10dBm if nothing else stated. Measured on Chipcon's CC1100EM reference design.

Parameter	Min	Typ	Max	Unit	Condition/Note
Differential load impedance		TBD		Ω	Follow CC1100EM reference design
Output power, highest setting		10		dBm	Output power is programmable, and full range is available in all frequency bands. Delivered to a 50Ω single-ended load via Chipcon reference RF matching network.
Output power, lowest setting		-30		dBm	Output power is programmable, and full range is available in all frequency bands. Delivered to a 50Ω single-ended load via Chipcon reference RF matching network.
Spurious emissions and harmonics, 433/868MHz			-36	dBm	25MHz – 1GHz
			-54	dBm	47-74, 87.5-118, 174-230, 470-862MHz
			-47	dBm	1800MHz-1900MHz (restricted band in Europe), when the operating frequency is below 900MHz (2 <sup>nd</sup> harmonic can not fall within this band when used in Europe)
			-30	dBm	Otherwise above 1GHz
Spurious emissions, 315/915MHz			-49.2	dBm EIRP	<200μV/m at 3m below 960MHz.
			-41.2	dBm EIRP	<500μV/m at 3m above 960MHz.
Harmonics 315MHz			-20	dBc	2 <sup>nd</sup> , 3 <sup>rd</sup> and 4 <sup>th</sup> harmonic when the output power is maximum 6mV/m at 3m. (-19.6dBm EIRP)
			-41.2	dBm	5 <sup>th</sup> harmonic
Harmonics 915MHz			-20	dBc	2 <sup>nd</sup> harmonic
			-41.2	dBm	3 <sup>rd</sup> , 4 <sup>th</sup> and 5 <sup>th</sup> harmonic

**Table 6: RF Transmit Parameters**

## 7 Crystal Oscillator

Tc = 25°C @ VDD = 3.0 V if nothing else is stated.

Parameter	Min	Typ	Max	Unit	Condition/Note
Crystal frequency	26	26	27	MHz	
Tolerance		±40		ppm	This is the total tolerance including a) initial tolerance, b) aging and c) temperature dependence. The acceptable crystal tolerance depends on RF frequency and channel spacing / bandwidth.
ESR			100	Ω	
Start-up time		300		μs	Measured on Chipcon's CC1100EM reference design. This parameter is to a large degree crystal dependent.

**Table 7: Crystal Oscillator Parameters**

## 8 Low Power RC Oscillator

Typical performance is for Tc = 25°C @ VDD = 3.0 V if nothing else is stated.

The values in the table are simulated results and will be updated in later versions of the data sheet.

Parameter	Min	Typ	Max	Unit	Condition/Note
Calibrated frequency	34.6	34.7	36	kHz	Calibrated RC Oscillator frequency is XTAL frequency divided by 750
Frequency accuracy after calibration			±0.2	%	
Temperature coefficient		+0.4		% / °C	Frequency drift when temperature changes after calibration
Supply voltage coefficient		+3		% / V	Frequency drift when supply voltage changes after calibration
Initial calibration time		2		ms	When the RC Oscillator is enabled, calibration is continuously done in the background as long as the crystal oscillator is running.
Wake-up period	58e-6		59650	Seconds	Programmable, dependent on XTAL frequency

**Table 8: RC Oscillator parameters**

## 9 Frequency Synthesizer Characteristics

Tc = 25°C @ VDD = 3.0 V if nothing else is stated. Measured on Chipcon's CC1100EM reference design.

Parameter	Min	Typ	Max	Unit	Condition/Note
Programmed frequency resolution	397	$F_{XOSC} / 2^{16}$	412	Hz	26MHz-27MHz crystal. The resolution (in Hz) is equal for all frequency bands.
Synthesizer frequency tolerance		±40		ppm	Given by crystal used. Required accuracy (including temperature and aging) depends on frequency band and channel bandwidth / spacing.
PLL turn-on / hop time			80	µs	Time from leaving the IDLE state until arriving in the RX, FSTXON or TX state, when not performing calibration. Crystal oscillator running.
PLL RX/TX and TX/RX settling time			10	µs	Settling time for the 1xIF frequency step from RX to TX, and vice versa.
PLL calibration time	0.69	18739 0.72	0.72	XOSC cycles ms	Calibration can be initiated manually, or automatically before entering or after leaving RX/TX. Min/typ/max time is for 27/26/26MHz crystal frequency.

**Table 9: Frequency Synthesizer Parameters**

## 10 Analog temperature sensor

The characteristics of the analog temperature sensor are listed in Table 10 below. Note that it is necessary to write 0xBF to the PTEST register to use the analog temperature sensor in the IDLE state.

The values in the table are simulated results and will be updated in later versions of the data sheet. Minimum / maximum values are valid over entire supply voltage range. Typical values are for 3.0V supply voltage.

Parameter	Min	Typ	Max	Unit	Condition/Note
Output voltage at -40°C	0.638	0.648	0.706	V	
Output voltage at 0°C	0.733	0.743	0.793	V	
Output voltage at +40°C	0.828	0.840	0.891	V	
Output voltage at +80°C	0.924	0.939	0.992	V	
Temperature coefficient	2.35	2.45	2.46	mV/°C	Fitted from -20°C to +80°C
Absolute error in calculated temperature	-14	-8	+14	°C	From -20°C to +80°C when assuming best fit for absolute accuracy: 0.763V at 0°C and 2.44mV / °C
Error in calculated temperature, calibrated	-2		+2	°C	From -20°C to +80°C when using 2.44mV / °C, after 1-point calibration at room temperature
Settling time after enabling		TBD		µs	
Current consumption increase when enabled		0.3		mA	

**Table 10: Analog Temperature Sensor Parameters**

## 11 DC Characteristics

The DC Characteristics of **CC1100** are listed in Table 11 below.

Tc = 25°C if nothing else stated.

Digital Inputs/Outputs	Min	Max	Unit	Condition
Logic "0" input voltage	0	0.7	V	
Logic "1" input voltage	VDD-0.7	VDD	V	
Logic "0" output voltage	0	0.5	V	For up to 4mA output current
Logic "1" output voltage	VDD-0.3	VDD	V	For up to 4mA output current
Logic "0" input current	N/A	-1	µA	Input equals 0V
Logic "1" input current	N/A	1	µA	Input equals VDD

**Table 11: DC Characteristics**

## 12 Power On Reset

When the power supply complies with the requirements in Table 12 below, proper Power-On-Reset functionality is guaranteed. Otherwise, the chip should be assumed to have unknown state until transmitting an  $SRES$  strobe over the SPI interface. It is recommended to transmit an  $SRES$  strobe after turning power on in any case. See section 27.1 on page 31 for a description of the recommended start up sequence after turning power on.

Parameter	Min	Typ	Max	Unit	Condition/Note
Power-up ramp-up time.			5	ms	From 0V until reaching 1.8V
Power off time	1			ms	Minimum time between power-on and power-off.

Table 12: Power-on Reset Requirements

## 13 Pin Configuration

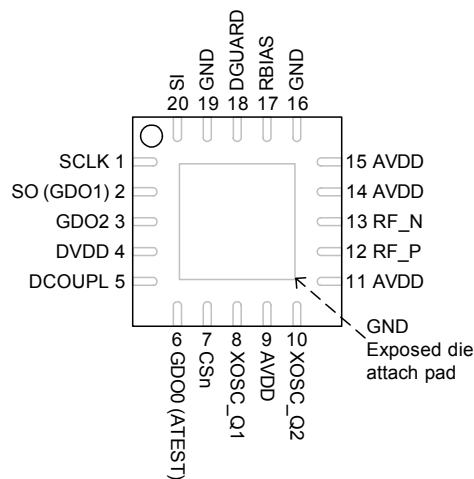

Figure 1: Pinout top view

Note: The exposed die attach pad **must** be connected to a solid ground plane as this is the main ground connection for the chip.

Pin #	Pin name	Pin type	Description
1	SCLK	Digital Input	Serial configuration interface, clock input
2	SO (GDO1)	Digital Output	Serial configuration interface, data output. Optional general output pin when CSn is high
3	GDO2	Digital Output	Digital output pin for general use: <ul style="list-style-type: none"> <li>• Test signals</li> <li>• FIFO status signals</li> <li>• Clear Channel Indicator</li> <li>• Clock output, down-divided from XOSC</li> <li>• Serial output RX data</li> </ul>
4	DVDD	Power (Digital)	1.8V-3.6V digital power supply for digital I/O's and for the digital core voltage regulator
5	DCOUPPL	Power (Digital)	1.6V-2.0V digital power supply output for decoupling. NOTE: This pin is intended for use with the <b>CC1100</b> only. It can not be used to provide supply voltage to other devices.
6	GDO0 (ATEST)	Digital I/O	Digital output pin for general use: <ul style="list-style-type: none"> <li>• Test signals</li> <li>• FIFO status signals</li> <li>• Clear Channel Indicator</li> <li>• Clock output, down-divided from XOSC</li> <li>• Serial output RX data</li> <li>• Serial input TX data</li> </ul> Also used as analog test I/O for prototype/production testing
7	CSn	Digital Input	Serial configuration interface, chip select
8	XOSC_Q1	Analog I/O	Crystal oscillator pin 1, or external clock input
9	AVDD	Power (Analog)	1.8V-3.6V analog power supply connection
10	XOSC_Q2	Analog I/O	Crystal oscillator pin 2
11	AVDD	Power (Analog)	1.8V-3.6V analog power supply connection
12	RF_P	RF I/O	Positive RF input signal to LNA in receive mode Positive RF output signal from PA in transmit mode
13	RF_N	RF I/O	Negative RF input signal to LNA in receive mode Negative RF output signal from PA in transmit mode
14	AVDD	Power (Analog)	1.8V-3.6V analog power supply connection
15	AVDD	Power (Analog)	1.8V-3.6V analog power supply connection
16	GND	Ground (Analog)	Analog ground connection
17	RBIAS	Analog I/O	External bias resistor for reference current
18	DGUARD	Power (Digital)	Power supply connection for digital noise isolation
19	GND	Ground (Digital)	Ground connection for digital noise isolation
20	SI	Digital Input	Serial configuration interface, data input

**Table 13: Pinout overview**

## 14 Circuit Description

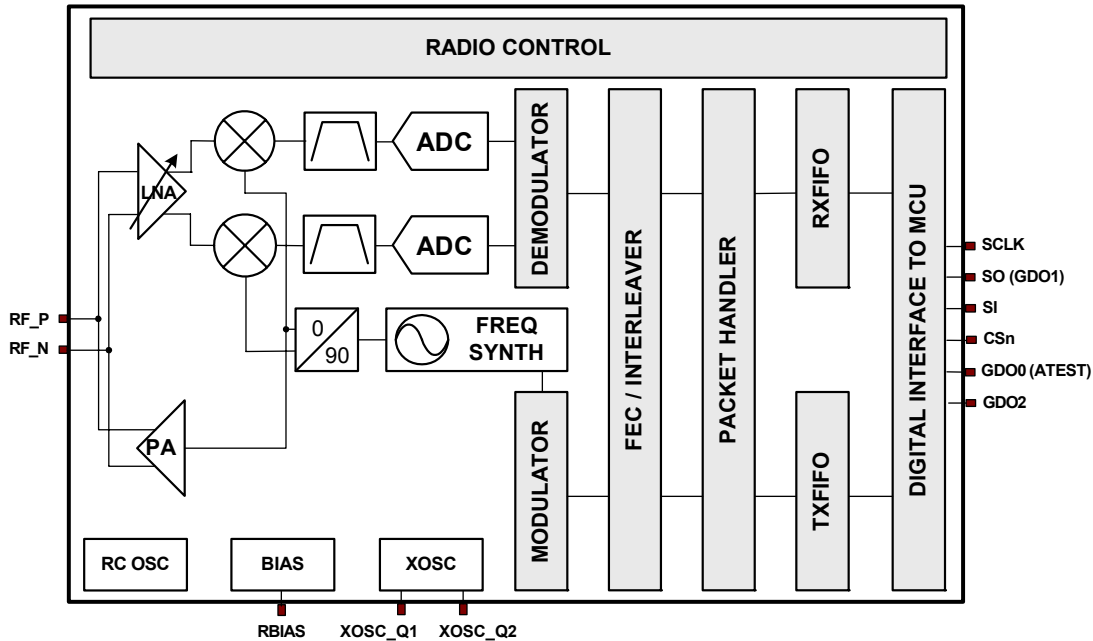

Figure 2: **CC1100** Simplified Block Diagram

A simplified block diagram of **CC1100** is shown in Figure 2.

**CC1100** features a low-IF receiver. The received RF signal is amplified by the low-noise amplifier (LNA) and down-converted in quadrature (I and Q) to the intermediate frequency (IF). At IF, the I/Q signals are digitised by the ADCs. Automatic gain control (AGC), fine channel filtering, demodulation bit/packet synchronization is performed digitally.

The transmitter part of **CC1100** is based on direct synthesis of the RF frequency. The

frequency synthesizer includes a completely on-chip LC VCO and a 90 degree phase shifter for generating the I and Q LO signals to the down-conversion mixers in receive mode.

A crystal is to be connected to XOSC\_Q1 and XOSC\_Q2. The crystal oscillator generates the reference frequency for the synthesizer, as well as clocks for the ADC and the digital part.

A 4-wire SPI serial interface is used for configuration and data buffer access.

The digital baseband includes support for channel configuration, packet handling and data buffering.

## 15 Application Circuit

Only a few external components are required for using the **CC1100**. The recommended application circuit is shown in Figure 3. The external components are described in Table 14, and typical values are given in Table 15.

### Bias resistor

The bias resistor R171 is used to set an accurate bias current.

### Balun and RF matching

C131, C121, L121 and L131 form a balun that converts the differential RF port on **CC1100** to a

single-ended RF signal (C124 is also needed for DC blocking). Together with an appropriate LC network, the balun components also transform the impedance to match a 50Ω antenna (or cable). Component values for the RF balun and LC network are easily found using the SmartRF® Studio software. Suggested values for 315MHz, 433MHz and 868/915MHz are listed in Table 15.

**Crystal**

The crystal oscillator uses an external crystal with two loading capacitors (C81 and C101). See section 33 on page 37 for details.

**Additional filtering**

Additional external components (e.g. an RF SAW filter) may be used in order to improve the performance in specific applications.

**Power supply decoupling**

The power supply must be properly decoupled close to the supply pins. Note that decoupling capacitors are not shown in the application circuit. The placement and the size of the decoupling capacitors are very important to achieve the optimum performance. Chipcon provides a reference design that should be followed closely.

Component	Description
C51	100nF decoupling capacitor for on-chip voltage regulator to digital part
C81/C101	Crystal loading capacitors, see section 33 on page 37 for details
C121/C131	RF balun/matching capacitors
C122/C123	RF LC filter/matching capacitors
C124	RF balun DC blocking capacitor
C125	RF LC filter DC blocking capacitor (only needed if there is a DC path in the antenna)
L121/L131	RF balun/matching inductors (inexpensive multi-layer type)
L122/L123	RF LC filter/matching filter inductor (inexpensive multi-layer type)
R171	56kΩ resistor for internal bias current reference
XTAL	26MHz-27MHz crystal, see section 33 on page 37 for details

**Table 14: Overview of external components (excluding supply decoupling capacitors)**

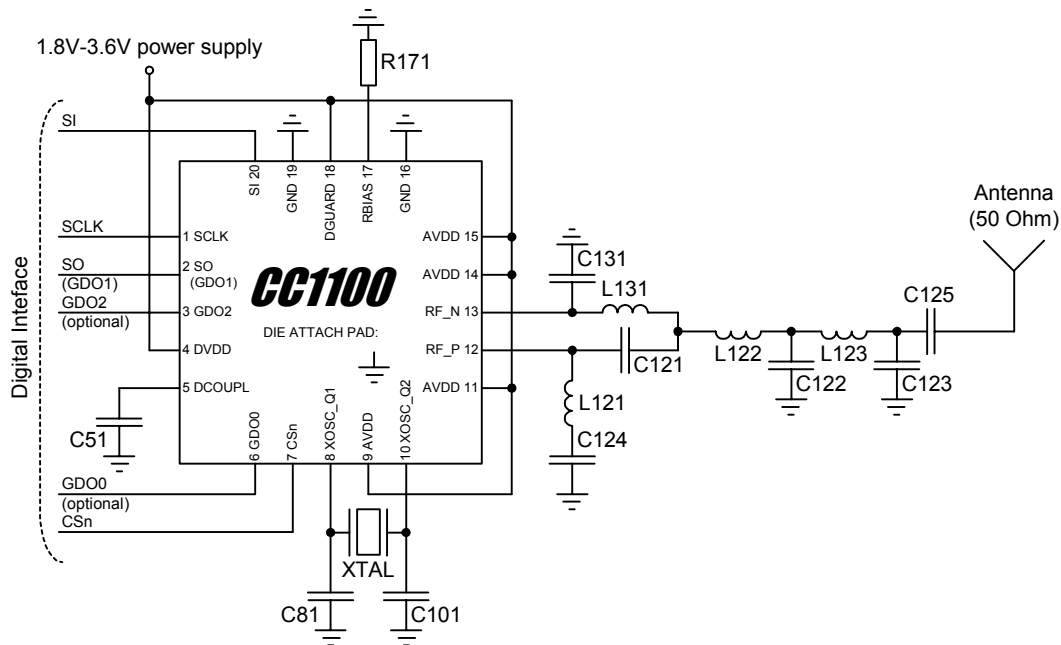

**Figure 3: Typical application and evaluation circuit (excluding supply decoupling capacitors)**

Component	Value at 315MHz	Value at 433MHz	Value at 868/915MHz
C51	100nF±10%, 0402 X5R		
C81	27pF±5%, 0402 NP0		
C101	27pF±5%, 0402 NP0		
C121	6.8pF±0.5pF, 0402 NP0	3.9pF±0.25pF, 0402 NP0	2.2pF±0.25pF, 0402 NP0
C122	12pF±5%, 0402 NP0	8.2pF±0.5pF, 0402 NP0	3.9pF±0.25pF, 0402 NP0
C123	6.8pF±0.5pF, 0402 NP0	5.6pF±0.5pF, 0402 NP0	3.3pF±0.25pF, 0402 NP0
C124	220pF±5%, 0402 NP0	220pF±5%, 0402 NP0	100pF±5%, 0402 NP0
C125 or C126	220pF±5%, 0402 NP0	220pF±5%, 0402 NP0	100pF±5%, 0402 NP0
C131	6.8pF±0.5pF, 0402 NP0	3.9pF±0.25pF, 0402 NP0	2.2pF±0.25pF, 0402 NP0
L121	33nH±5%, 0402 monolithic	27nH±5%, 0402 monolithic	12nH±5%, 0402 monolithic
L122	18nH±5%, 0402 monolithic	22nH±5%, 0402 monolithic	5.6nH±0.3nH, 0402 monolithic
L123	33nH±5%, 0402 monolithic	27nH±5%, 0402 monolithic	12nH±5%, 0402 monolithic
L131	33nH±5%, 0402 monolithic	27nH±5%, 0402 monolithic	12nH±5%, 0402 monolithic
R171	56kΩ±1%, 0402		
XTAL	26.0MHz surface mount crystal		

**Table 15: Bill Of Materials for the application circuit (subject to changes)**

## 16 Configuration Overview

**CC1100** can be configured to achieve optimum performance for many different applications. Configuration is done using the SPI interface. The following key parameters can be programmed:

- Power-down / power up mode
- Crystal oscillator power-up / power-down
- Receive / transmit mode
- RF channel selection
- Data rate
- Modulation format
- RX channel filter bandwidth
- RF output power
- Data buffering with separate 64-byte receive and transmit FIFOs

- Packet radio hardware support
- Forward Error Correction with interleaving
- Data Whitening
- Wake-On-Radio (WOR)

Details of each configuration register can be found in section 37, starting on page 40.

Figure 4 shows a simplified state diagram that explains the main **CC1100** states, together with typical usage and current consumption. For detailed information on controlling the **CC1100** state machine, and a complete state diagram, see section 27, starting on page 30.



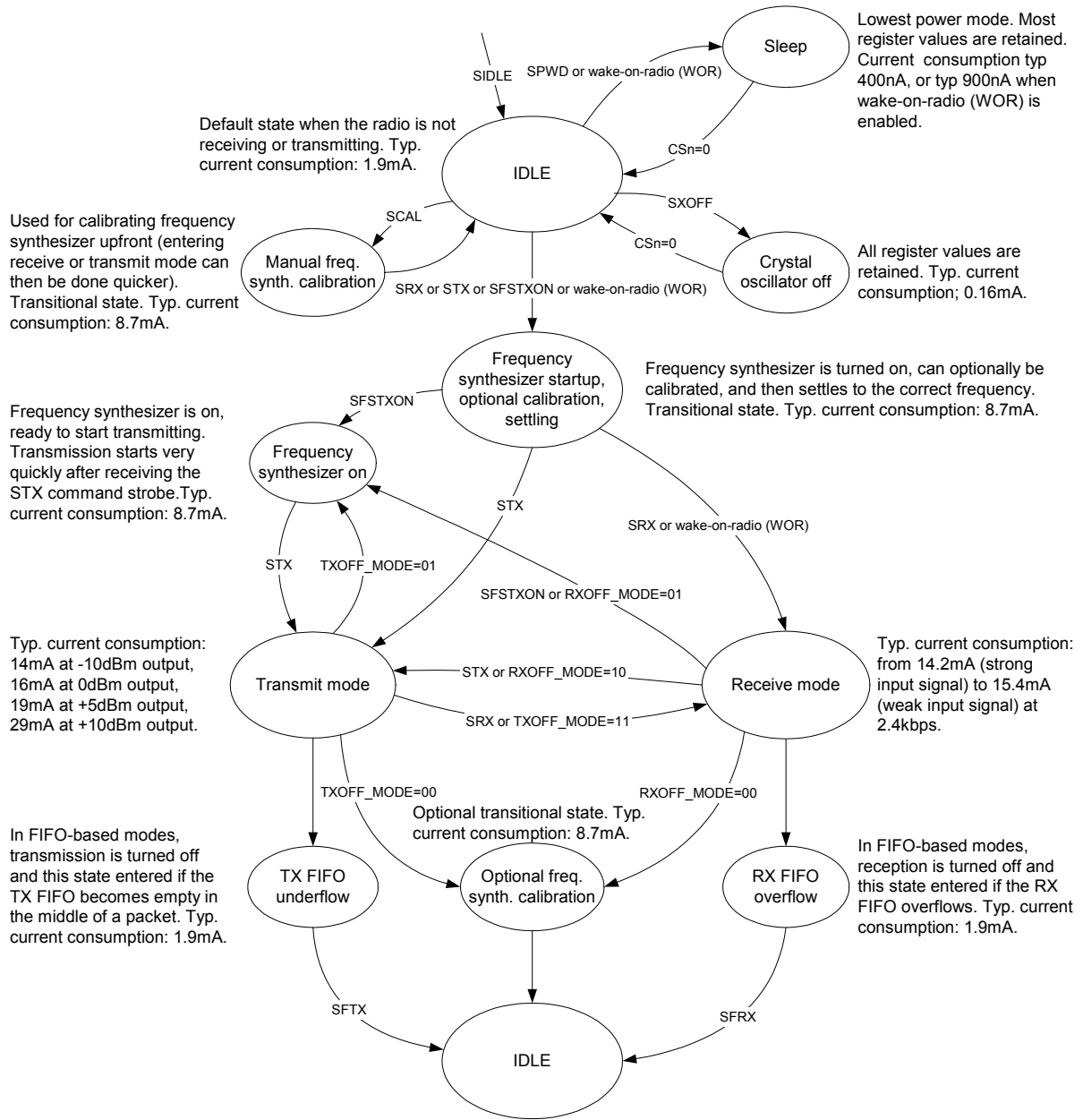

Figure 4: Simplified state diagram, with typical usage and current consumption

## 17 Configuration Software

CC1100 can be configured using the SmartRF® Studio software, available for download from <http://www.chipcon.com>. The SmartRF® Studio software is highly recommended for obtaining

optimum register settings, and for evaluating performance and functionality. A screenshot of the SmartRF® Studio user interface for CC1100 is shown in Figure 5.

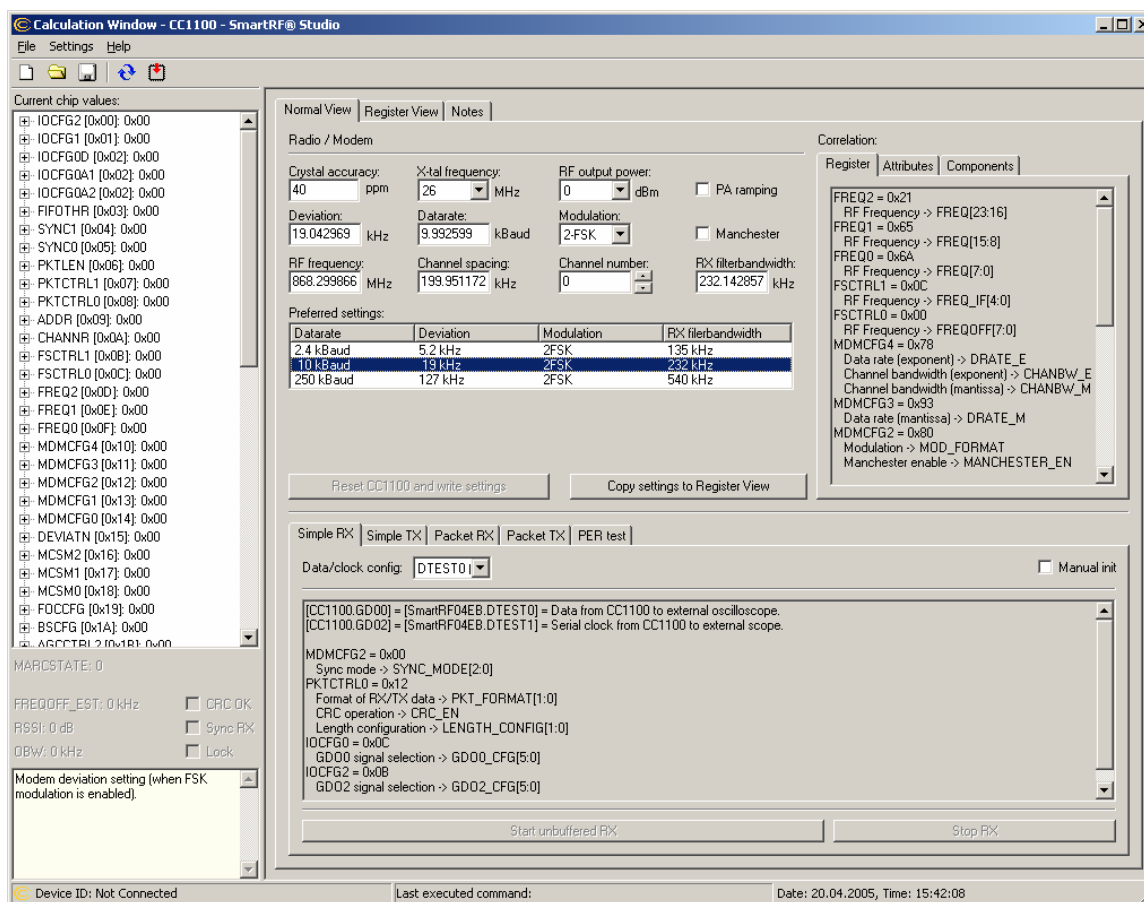

Figure 5: SmartRF® Studio user interface

## 18 4-wire Serial Configuration and Data Interface

**CC1100** is configured via a simple 4-wire SPI-compatible interface (SI, SO, SCLK and CSn) where **CC1100** is the slave. This interface is also used to read and write buffered data. All address and data transfer on the SPI interface is done most significant bit first.

All transactions on the SPI interface start with a header byte containing a read/write bit, a burst access bit and a 6-bit address.

During address and data transfer, the CSn pin (Chip Select, active low) must be kept low. If CSn goes high during the access, the transfer will be cancelled.

When CSn goes low, the MCU must wait until the **CC1100** SO pin goes low before starting to transfer the header byte. This indicates that the voltage regulator has stabilized and the crystal is running. Unless the chip was in the SLEEP or XOFF states, the SO pin will always go low immediately after taking CSn low.

### 18.1 Chip Status Byte

When the header byte is sent on the SPI interface, the chip status byte is sent by the **CC1100** on the SO pin. The status byte contains key status signals, useful for the MCU. The first bit, s7, is the CHIP\_RDYn signal; this signal must go low before the first positive edge of SCLK. The CHIP\_RDYn signal indicates that the crystal is running and the regulated digital supply voltage is stable.

Bit 6, 5 and 4 comprises the STATE value. This value reflects the state of the chip. When idle the XOSC and power to the digital core is on, but all other modules are in power down. The frequency and channel configuration should only be updated when the chip is in this state. The RX state will be active when the chip is in receive mode. Likewise, TX is active when the chip is transmitting.

The last four bits (3:0) in the status byte contains `FIFO_BYTES_AVAILABLE`. For read operations, the `FIFO_BYTES_AVAILABLE` field contains the number of bytes available for reading from the RX FIFO. For write operations, the `FIFO_BYTES_AVAILABLE` field contains the number of bytes free for writing into the TX FIFO. When `FIFO_BYTES_AVAILABLE=15`, 15 or more bytes are available/free.

## 18.2 Register Access

The configuration registers on the **CC1100** are located on SPI addresses from `0x00` to `0x2F`. Table 29 on page 42 lists all configuration registers. The detailed description of each register is found in Section 37.1, starting on page 45. All configuration registers can be both written to and read. The read/write bit controls if the register should be written to or read. When writing to registers, the status byte is sent on the `SO` pin each time a data byte to be written is transmitted on the `SI` pin.

Registers with consecutive addresses can be accessed in an efficient way by setting the burst bit in the address header. The address sets the start address in an internal address counter. This counter is incremented by one each new byte (every 8 clock pulses). The burst access is either a read or a write access and must be terminated by setting `CSn` high.

For register addresses in the range `0x30-0x3D`, the "burst" bit is used to select between status registers and command strobes (see below). The status registers can only be read. Burst read is not available for status registers, so they must be read one at a time.

## 18.3 Command Strokes

Command Strokes may be viewed as single byte instructions to **CC1100**. By addressing a Command Strobe register, internal sequences will be started. These commands are used to disable the crystal oscillator, enable receive mode, enable wake-on-radio etc. The 14 command strobes are listed in Table 28 on page 41.

The command strobe registers are accessed in the same way as for a register write operation, but no data is transferred. That is, only the R/W bit (set to 0), burst access (set to 0) and the six address bits (in the range `0x30` through `0x3D`) are written. A command strobe

may be followed by any other SPI access without pulling `CSn` high. The command strobes are executed immediately, with the exception of the `SPWD` and the `SXOFF` strobes that are executed when `CSn` goes high.

## 18.4 FIFO Access

The 64-byte TX FIFO and the 64-byte RX FIFO are accessed through the `0x3F` addresses. When the read/write bit is zero, the TX FIFO is accessed, and the RX FIFO is accessed when the read/write bit is one.

The TX FIFO is write-only, while the RX FIFO is read-only.

The burst bit is used to determine if FIFO access is single byte or a burst access. The single byte access method expects address with burst bit set to zero and one data byte. After the data byte a new address is expected; hence, `CSn` can remain low. The burst access method expects one address byte and then consecutive data bytes until terminating the access by setting `CSn` high.

The following header bytes access the FIFOs:

- `0x3F`: Single byte access to TX FIFO
- `0x7F`: Burst access to TX FIFO
- `0xBF`: Single byte access to RX FIFO
- `0xFF`: Burst access to RX FIFO

When writing to the TX FIFO, the status byte (see Section 18.1) is output for each new data byte on `SO`, as shown in Figure 6. This status byte can be used to detect TX FIFO underflow while writing data to the TX FIFO. Note that the status byte contains the number of bytes free *before* writing the byte in progress to the TX FIFO. When the last byte that fits in the TX FIFO is transmitted to the `SI` pin, the status byte received concurrently on the `SO` pin will indicate that one byte is free in the TX FIFO.

The transmit FIFO may be flushed by issuing a `SFTX` command strobe. Similarly, a `SFRX` command strobe will flush the receive FIFO. Both FIFOs are cleared when going to the SLEEP state.

## 18.5 PATABLE Access

The `0x3E` address is used to access the `PATABLE`, which is used for selecting PA power control settings. The SPI expects up to eight data bytes after receiving the address.

By programming the `PATABLE`, controlled PA power ramp-up and ramp-down can be achieved, as well as ASK modulation shaping for reduced bandwidth. See section 32 on page 36 for output power programming details.

The `PATABLE` is an 8-byte table that defines the PA control settings to use for each of the eight PA power values (selected by the 3-bit value `FREND0.PA_POWER`). The table is written to and read from the lowest setting (0) to the highest (7), one byte at a time. An index counter is used to control the access to the table. This counter is incremented each time a byte is read or written to the table, and set to the lowest index when `CSn` is high. When the highest value is reached the counter restarts at zero.

The access to the `PATABLE` is either single byte or burst access depending on the burst bit. When using burst access the index counter will count up; when reaching 7 the counter will restart at 0. The read/write bit controls whether the access is a write access (`R/W=0`) or a read access (`R/W=1`).

If one byte is written to the `PATABLE` and this value is to be read out then `CSn` must be set high before the read access in order to set the index counter back to zero.

Note that the content of the `PATABLE` is lost when entering the `SLEEP` state, except for the first byte (index 0).

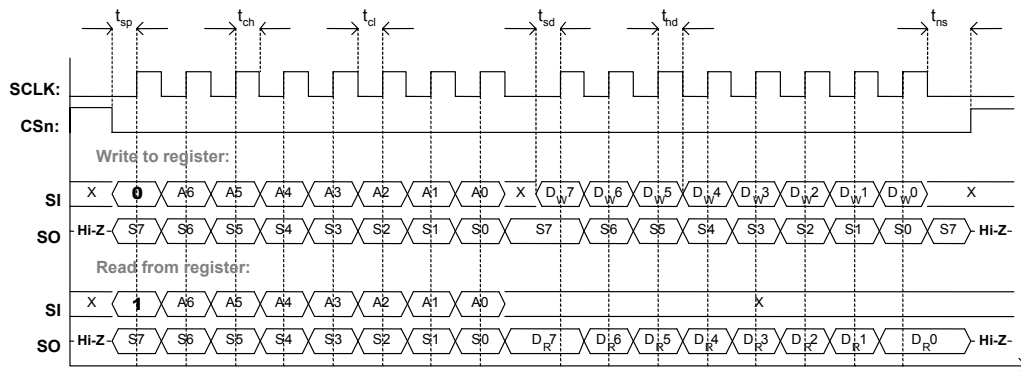

Figure 6: Configuration registers write and read operations

Parameter	Description	Min	Max
$F_{SCLK}$	SCLK frequency	0	10MHz
$t_{sp,pd}$	CSn low to positive edge on SCLK, in power-down mode	TBD $\mu$ s	-
$t_{sp}$	CSn low to positive edge on SCLK, in active mode	TBDns	-
$t_{ch}$	Clock high	50ns	-
$t_{cl}$	Clock low	50ns	-
$t_{rise}$	Clock rise time	-	TBDns
$t_{fall}$	Clock fall time	-	TBDns
$t_{sd}$	Setup data to positive edge on SCLK	TBDns	-
$t_{hd}$	Hold data after positive edge on SCLK	TBDns	-
$t_{ns}$	Negative edge on SCLK to CSn high.	TBDns	-

Table 16: SPI interface timing requirements

Bits	Name	Description																											
7	CHIP_RDYn	Stays high until power and crystal have stabilized. Should always be low when using the SPI interface.																											
6:4	STATE[2:0]	Indicates the current main state machine mode <table border="1"> <thead> <tr> <th>Value</th> <th>State</th> <th>Description</th> </tr> </thead> <tbody> <tr> <td>000</td> <td>Idle</td> <td>IDLE state (Also reported for some transitional states instead of SETTling or CALIBRATE, due to a small error)</td> </tr> <tr> <td>001</td> <td>RX</td> <td>Receive mode</td> </tr> <tr> <td>010</td> <td>TX</td> <td>Transmit mode</td> </tr> <tr> <td>011</td> <td>FSTXON</td> <td>Fast TX ready</td> </tr> <tr> <td>100</td> <td>CALIBRATE</td> <td>Frequency synthesizer calibration is running</td> </tr> <tr> <td>101</td> <td>SETTLING</td> <td>PLL is settling</td> </tr> <tr> <td>110</td> <td>RXFIFO_OVERFLOW</td> <td>RX FIFO has overflowed. Read out any useful data, then flush the FIFO with SFRX</td> </tr> <tr> <td>111</td> <td>TXFIFO_UNDERFLOW</td> <td>TX FIFO has underflowed. Acknowledge with SFTX</td> </tr> </tbody> </table>	Value	State	Description	000	Idle	IDLE state (Also reported for some transitional states instead of SETTling or CALIBRATE, due to a small error)	001	RX	Receive mode	010	TX	Transmit mode	011	FSTXON	Fast TX ready	100	CALIBRATE	Frequency synthesizer calibration is running	101	SETTLING	PLL is settling	110	RXFIFO_OVERFLOW	RX FIFO has overflowed. Read out any useful data, then flush the FIFO with SFRX	111	TXFIFO_UNDERFLOW	TX FIFO has underflowed. Acknowledge with SFTX
Value	State	Description																											
000	Idle	IDLE state (Also reported for some transitional states instead of SETTling or CALIBRATE, due to a small error)																											
001	RX	Receive mode																											
010	TX	Transmit mode																											
011	FSTXON	Fast TX ready																											
100	CALIBRATE	Frequency synthesizer calibration is running																											
101	SETTLING	PLL is settling																											
110	RXFIFO_OVERFLOW	RX FIFO has overflowed. Read out any useful data, then flush the FIFO with SFRX																											
111	TXFIFO_UNDERFLOW	TX FIFO has underflowed. Acknowledge with SFTX																											
3:0	FIFO_BYTES_AVAILABLE[3:0]	The number of bytes available in the RX FIFO or free bytes in the TX FIFO (depends on the read/write-bit). If FIFO_BYTES_AVAILABLE=15, it indicates that 15 or more bytes are available/free.																											

**Table 17: Status byte summary**

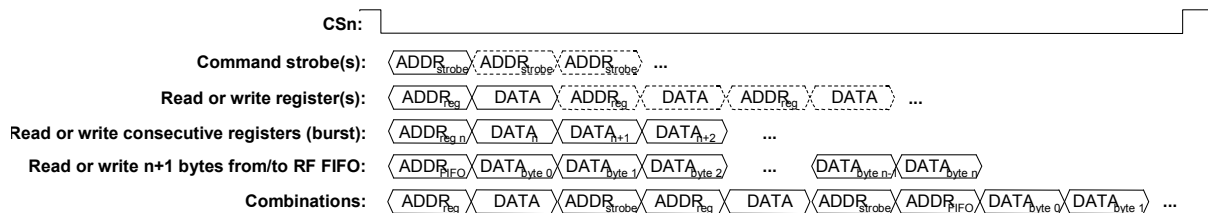

**Figure 7: Register access types**

## 19 Microcontroller Interface and Pin Configuration

In a typical system, **CC1100** will interface to a microcontroller. This microcontroller must be able to:

- Program **CC1100** into different modes,
- Read and write buffered data
- Read back status information via the 4-wire SPI-bus configuration interface (SI, SO, SCLK and CSn).

### 19.1 Configuration Interface

The microcontroller uses four I/O pins for the SPI configuration interface (SI, SO, SCLK and

CSn). The SPI is described in Section 18 on page 18.

### 19.2 General Control and Status Pins

The **CC1100** has two dedicated configurable pins and one shared pin that can output internal status information useful for control software. These pins can be used to generate interrupts on the MCU. See Section 35 page 38 for more details of the signals that can be programmed. The dedicated pins are called GDO0 and GDO2. The shared pin is the SO pin in the SPI interface. The default setting for GDO1/SO is 3-state output. By selecting any other of the programming options the

GDO1/SO pin will become a generic pin. When CS<sub>n</sub> is low, the pin will always function as a normal SO pin.

In the synchronous and asynchronous serial modes, the GDO0 pin is used as a serial TX data input pin while in transmit mode.

The GDO0 pin can also be used for an on-chip analog temperature sensor. By measuring the voltage on the GDO0 pin with an external ADC, the temperature can be calculated. Specifications for the temperature sensor are found in section 10 on page 11.

The temperature sensor output is usually only available when the frequency synthesizer is enabled (e.g. the MANCAL, FSTXON, RX and TX states). It is necessary to write 0xBF to the PTEST register to use the analog temperature sensor in the IDLE state. Before leaving the IDLE state, the PTEST register should be restored to its default value (0x7F).

### 19.3 Optional radio control feature

The **CC1100** has an optional way of controlling the radio, by reusing SI, SCLK and CS<sub>n</sub> from the SPI interface. This feature allows for a simple three-pin control of the major states of the radio: SLEEP, IDLE, RX and TX.

## 20 Data Rate Programming

The data rate used when transmitting, or the data rate expected in receive is programmed by the MDMCFG3.DRATE\_M and the MDMCFG4.DRATE\_E configuration registers. The data rate is given by the formula below. As the formula shows, the programmed data rate depends on the crystal frequency.

$$R_{DATA} = \frac{(256 + DRATE\_M) \cdot 2^{DRATE\_E}}{2^{28}} \cdot f_{XOSC}$$

The following approach can be used to find suitable values for a given data rate:

## 21 Receiver Channel Filter Bandwidth

In order to meet different channel width requirements, the receiver channel filter is programmable. The MDMCFG4.CHANBW\_E and MDMCFG4.CHANBW\_M configuration registers control the receiver channel filter bandwidth, which scales with the crystal oscillator frequency. The following formula gives the

This optional functionality is enabled with the MCSM0.PIN\_CTRL\_EN configuration bit.

State changes are commanded as follows when CS<sub>n</sub> is high the SI and SCLK is set to the desired state according to Table 18. When CS<sub>n</sub> goes low the state of SI and SCLK is latched and a command strobe is generated internally according to the pin configuration. It is only possible to change state with this functionality. That means that for instance RX will not be restarted if SI and SCLK are set to RX and CS<sub>n</sub> toggles. When CS<sub>n</sub> is low the SI and SCLK has normal SPI functionality.

CS <sub>n</sub>	SCLK	SI	Function
1	X	X	Chip unaffected by SCLK/SI
↓	0	0	Generates SPWD strobe
↓	0	1	Generates STX strobe
↓	1	0	Generates SIDLE strobe
↓	1	1	Generates SRX strobe
0	SPI mode	SPI mode	SPI mode (wakes up into IDLE if in SLEEP/XOFF)

**Table 18: Optional pin control coding**

All pin control command strobes are executed immediately, except the SPWD strobe, which is delayed until CS<sub>n</sub> goes high.

$$DRATE\_E = \left\lceil \log_2 \left( \frac{R_{DATA} \cdot 2^{20}}{f_{XOSC}} \right) \right\rceil$$

$$DRATE\_M = \frac{R_{DATA} \cdot 2^{28}}{f_{XOSC} \cdot 2^{DRATE\_E}} - 256$$

If DRATE\_M is rounded to the nearest integer and becomes 256, increment DRATE\_E and use DRATE\_M=0.

relation between the register settings and the channel filter bandwidth:

$$BW_{channel} = \frac{f_{XOSC}}{8 \cdot (4 + CHANBW\_M) \cdot 2^{CHANBW\_E}}$$

The **CC1100** supports channel filter bandwidths between 54-63kHz and 600-700kHz<sup>1</sup>. Above 300kHz bandwidth, however, the sensitivity and blocking performance may be somewhat degraded.

For best performance, the channel filter bandwidth should be selected so that the signal bandwidth occupies at most 80% of the channel filter bandwidth. The channel centre

<sup>1</sup> The combination of `CHANBW_E=0` and `CHANBW_M=0` is not supported. Exact limits depend on crystal frequency.

tolerance due to crystal accuracy should also be subtracted from the signal bandwidth. The following example illustrates this:

With the channel filter bandwidth set to 500kHz, the signal should stay within 80% of 500kHz, which is 400kHz. Assuming 915MHz frequency and  $\pm 20$ ppm frequency uncertainty for both the transmitting device and the receiving device, the total frequency uncertainty is  $\pm 40$ ppm of 915MHz, which is  $\pm 37$ kHz. If the whole transmitted signal bandwidth is to be received within 400kHz, the transmitted signal bandwidth should be maximum 400kHz-2·37kHz, which is 326kHz.

## 22 Demodulator, Symbol Synchronizer and Data Decision

**CC1100** contains an advanced and highly configurable demodulator. Channel filtering and frequency offset compensation is performed digitally. To generate the RSSI level (see section 25.2 for more information) the signal level in the channel is estimated. Data filtering is also included for enhanced performance.

### 22.1 Frequency Offset Compensation

When using 2-FSK, GFSK or MSK modulation, the demodulator will compensate for the offset between the transmitter and receiver frequency, within certain limits, by estimating the centre of the received data. This value is available in the `FREQEST` status register.

By issuing the `SAFC` command strobe, the measured offset, `FREQEST.FREQOFF_EST`, can automatically be used to adjust the frequency offset programming in the frequency synthesizer. This will add the current RX frequency offset estimate to the value in `FSCTRL0.FREQOFF`, which adjust the synthesizer frequency. Thus, the frequency offset will be compensated in both RX and TX when the `SAFC` command strobe is used.

To avoid compensating for frequency offsets measured without a valid signal in the RF channel, `FREQEST.FREQOFF_EST` is copied to an internal register when issuing the `SAFC` strobe in RX, and when a synch word is detected. If `SAFC` was issued in RX, this internal value is added to `FSCTRL0.FREQOFF` after exiting RX. Issuing `SAFC` when not in RX will immediately add the internal register value to `FSCTRL0.FREQOFF`. Thus, the `SAFC` strobe

should be issued when currently receiving a packet, or outside the RX state.

Note that frequency offset compensation is not supported for ASK or OOK modulation.

### 22.2 Bit Synchronization

The bit synchronization algorithm extracts the clock from the incoming symbols. The algorithm requires that the expected data rate is programmed as described in Section 20 on page 22. Re-synchronization is performed continuously to adjust for error in the incoming symbol rate.

### 22.3 Byte synchronization

Byte synchronization is achieved by a continuous sync word search. The sync word is a 16 or 32 bit configurable field that is automatically inserted at the start of the packet by the modulator in transmit mode. The demodulator uses this field to find the byte boundaries in the stream of bits. The sync word will also function as a system identifier, since only packets with the correct predefined sync word will be received. The sync word detector correlates against the user-configured 16-bit sync word. The correlation threshold can be set to 15/16 bits match or 16/16 bits match. The sync word can be further qualified using the preamble quality indicator mechanism described below and/or a carrier sense condition. The sync word is programmed with `SYNC1` and `SYNC0`.

In order to make false detections of sync words less likely, a mechanism called preamble quality indication (PQI) can be used to qualify the sync word. A threshold value for

the preamble quality must be exceeded in order for a detected sync word to be accepted.

See section 25.1 on page 27 for more details.

## 23 Packet Handling Hardware Support

The **CC1100** has built-in hardware support for packet oriented radio protocols.

In transmit mode, the packet handler will add the following elements to the packet stored in the TX FIFO:

- A programmable number of preamble bytes.
- A two byte Synchronization Word. Can be duplicated to give a 4-byte sync word.
- Optionally whiten the data with a PN9 sequence.
- Optionally Interleave and Forward Error Code the data.
- Optionally compute and add a CRC checksum over the data field.

In receive mode, the packet handling support will de-construct the data packet:

- Preamble detection.
- Sync word detection.
- Optional one byte address check.
- Optionally compute and check CRC.
- Optionally append two status bytes (see Table 19 and Table 20) with RSSI value, Link Quality Indication and CRC status.

Bit	Field name	Description
7:0	RSSI	RSSI value, bit 6:2 of RSSI register. This number is 2's complement and implicit a negative number

**Table 19: Received packet status byte 1**

Bit	Field name	Description
7	CRC_OK	1: CRC for received data OK (or CRC disabled) 0: CRC error in received data
6:0	LQI	Indicating the link quality

**Table 20: Received packet status byte 1**

The recommended setting is 4-byte preamble and 2-byte sync word.

Note that register fields that control the packet handling features should only be altered when **CC1100** is in the IDLE state.

### 23.1 Data whitening

From a radio perspective, the ideal over the air data are random and DC free. This results in the smoothest power distribution over the occupied bandwidth. This also gives the regulation loops in the receiver uniform operation conditions (no data dependencies).

Real world data often contain long sequences of zeros and ones. Performance can then be improved by whitening the data before transmitting, and de-whitening in the receiver. With **CC1100**, this can be done automatically by setting `PKTCTRL0.WHITE_DATA=1`. All data, except the preamble and the sync word, are then XOR-ed with a 9-bit pseudo-random (PN9) sequence before being transmitted. At the receiver end, the data are XOR-ed with the same pseudo-random sequence. This way, the whitening is reversed, and the original data appear in the receiver.

Setting `PKTCTRL0.WHITE_DATA=1` is recommended for all uses, except when over-the-air compatibility with other systems is needed.

### 23.2 Packet format

The format of the data packet can be configured and consists of the following items:

- Preamble
- Synchronization word
- Length byte or constant programmable packet length
- Optional Address byte
- Payload
- Optional 2 byte CRC

The preamble pattern is an alternating sequence of ones and zeros (01010101...). The minimum length of the preamble is programmable. When enabling TX, the modulator will start transmitting the preamble. When the programmed number of preamble bytes has been transmitted, the modulator will send the sync word and then data from the TX



FIFO if data is available. If the TX FIFO is empty, the modulator will continue to send preamble bytes until the first byte is written to the TX FIFO. The modulator will then send the sync word and then the data bytes.

The number of preamble bytes is programmed with the `MDMCFG1.NUM_PREAMBLE` value.

The synchronization word is a two-byte value set in the `SYNC1` and `SYNC0` registers. The sync word provides byte synchronization of the incoming packet. A one-byte synch word can be emulated by setting the `SYNC1` value to the preamble pattern. It is also possible to emulate a 32 bit sync word by using `MDMCFG2.SYNC_MODE=3` or `7`. The sync word will then be repeated twice.

**CC1100** supports both constant packet length protocols and variable length protocols. Variable or fixed packet length mode can be used for packet up to 255 bytes. For longer packets, infinite packet length mode must be used.

Fixed packet length mode is selected by setting `PKTCTRL0.LENGTH_CONFIG=0`. The desired packet length is set by the `PKTLEN` register. The packet length is defined as the payload data, excluding the length byte and the optional automatic CRC. In variable length mode, `PKTCTRL0.LENGTH_CONFIG=1`, the packet length is configured by the first byte after the sync word. The `PKTLEN` register is used to set the maximum packet length allowed in RX. Any packet received with a length byte with a value greater than `PKTLEN` will be discarded.

With `PKTCTRL0.LENGTH_CONFIG=2`, the packet length is set to infinite and transmission and reception will continue until turned off manually. The infinite mode can be turned off while a packet is being transmitted or received. As described in the next section, this can be used to support packet formats with different length configuration than natively supported by **CC1100**.

Note that the minimum packet length supported (excluding the optional length byte and CRC) is one byte of payload data.

### 23.2.1 Arbitrary length field configuration

The fixed length field can be reprogrammed during receive and transmit. This opens the possibility to have a different length field configuration than supported for variable length packets. At the start of reception, the packet length is set to a large value. The MCU reads out enough bytes to interpret the length field in the packet. Then the `PKTLEN` value is set according to this value. The end of packet will occur when the byte counter in the packet handler is equal to the `PKTLEN` register. Thus, the MCU must be able to program the correct length, before the internal counter reaches the packet length.

By utilizing the infinite packet length option, arbitrary packet length is available. At the start of the packet, the infinite mode must be active. When less than 256 bytes remains of the packet, the MCU sets the `PKTLEN` register to `mod(length, 256)`, disables infinite packet length and activates fixed length packets. When the internal byte counter reaches the `PKTLEN` value, the transmission or reception ends. Automatic CRC appending/checking can be used (by setting `PKTCTRL0.CRC_EN` to 1).

When for example a 454-byte packet is to be transmitted, the MCU does the following:

- Set `PKTCTRL0.LENGTH_CONFIG=2` (10).
- Pre-program the `PKTLEN` register to `mod(454,256)=198`.
- Transmit at least 198 bytes, for example by filling the 64-byte TX FIFO four times (256 bytes transmitted).
- Set `PKTCTRL0.LENGTH_CONFIG=0` (00).
- The transmission ends when the packet counter reaches 198. A total of  $256+198=454$  bytes are transmitted.

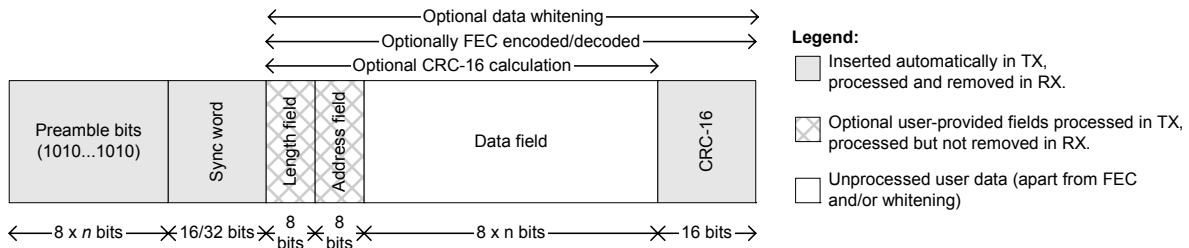

Figure 8: Packet Format

### 23.3 Packet filtering in Receive Mode

CC1100 supports two different packet-filtering criteria; address filtering and maximum length filtering.

Setting `PKTCTRL1.ADR_CHK` to any other value than zero enables the packet address filter. The packet handler engine will compare the destination address byte in the packet with the programmed node address in the `ADDR` register and the `0x00` broadcast address when `PKTCTRL1.ADR_CHK=10` or both `0x00` and `0xFF` broadcast addresses when `PKTCTRL1.ADR_CHK=11`. If the received address matches a valid address, the packet is received and written into the RX FIFO. If the address match fails, the packet is discarded.

In the variable packet length mode the `PKTLEN.PACKET_LENGTH` register value is used to set the maximum allowed packet length. If the received length byte has a larger value than this, the packet is discarded.

In both cases, receive mode is restarted after discarding the current packet (regardless of the `MCSM1.RXOFF_MODE` setting).

### 23.4 Packet Handling in Transmit Mode

The payload that is to be transmitted must be written into the TX FIFO. The first byte written must be the length byte when variable packet length is enabled. The length byte has a value equal to the payload of the packet (including the optional address byte). If fixed packet length is enabled, then the first byte written to the TX FIFO is interpreted as the destination address, if this feature is enabled in the device that receives the packet.

The modulator will first send the programmed number of preamble bytes. If data is available in the TX FIFO, the modulator will send the two-byte (optionally 4-byte) sync word and then the payload in the TX FIFO. If CRC is enabled, the checksum is calculated over all

the data pulled from the TX FIFO and the result is sent as two extra bytes at the end of the payload data.

If whitening is enabled, the length byte, payload data and the two CRC bytes will be whitened. This is done before the optional FEC/Interleaver stage. Whitening is enabled by setting `PKTCTRL0.WHITE_DATA=1`.

If FEC/Interleaving is enabled, the length byte, payload data and the two CRC bytes will be scrambled by the interleaver, and FEC encoded before being modulated.

### 23.5 Packet Handling in Receive Mode

In receive mode, the demodulator and packet handler will search for a valid preamble and the sync word. When found, the demodulator has obtained both bit and byte synchronism and will receive the first payload byte.

If FEC/Interleaving is enabled, the FEC decoder will start to decode the first payload byte. The interleaver will de-scramble the bits before any other processing is done to the data.

If whitening is enabled, the data will be de-whitened at this stage.

When variable packet length is enabled, the first byte is the length byte. The packet handler stores this value as the packet length and receives the number of bytes indicated by the length byte. If fixed packet length is used, the packet handler will accept the programmed number of bytes.

Next, the packet handler optionally checks the address and only continues the reception if the address matches. If automatic CRC check is enabled, the packet handler computes CRC and matches it with the appended CRC checksum.

At the end of the payload, the packet handler will optionally write two extra packet status bytes (see Table 19 and Table 20) that contain

CRC status, link quality indication and RSSI

value.

## 24 Modulation Formats

**CC1100** supports amplitude, frequency and phase shift modulation formats. The desired modulation format is set in the `MDMCFG2.MOD_FORMAT` register.

Optionally, the data stream can be Manchester coded by the modulator and decoded by the demodulator. This option is enabled by setting `MDMCFG2.MANCHESTER_EN=1`. Manchester encoding is not supported at the same time as using the FEC/Interleaver option. Manchester coding can be used with the 2-ary modulation formats (2-FSK, GFSK, ASK/OOK and MSK).

### 24.1 Frequency Shift Keying

2-FSK can optionally be shaped by a Gaussian filter with `BT=1`, producing a GFSK modulated signal.

The frequency deviation is programmed with the `DEVIATION_M` and `DEVIATION_E` values in the `DEVIATN` register. The value has an exponent/mantissa form, and the resultant deviation is given by:

$$f_{dev} = \frac{f_{xosc}}{2^{17}} \cdot (8 + DEVIATION\_M) \cdot 2^{DEVIATION\_E}$$

The symbol encoding is shown in Table 21.

Format	Symbol	Coding
2-FSK/GFSK	'0'	- Deviation
	'1'	+ Deviation

**Table 21: Symbol encoding for 2-FSK/GFSK modulation**

## 25 Received Signal Qualifiers and Link Quality Information

**CC1100** has several qualifier values that are used to increase the requirements that must be fulfilled before a search for a valid sync word is started.

### 25.1 Preamble Quality Threshold (PQT)

The Preamble Quality Threshold (PQT) sync-word qualifier adds the requirement that the received sync word must be preceded with a preamble with a quality above the programmed threshold.

### 24.2 Minimum Shift Keying

When using MSK<sup>2</sup>, the complete transmission (preamble, sync word and payload) will be MSK modulated.

Phase shifts are performed with a constant transition time. This means that the rate of change for the 180-degree transition is twice that of the 90-degree transition.

The fraction of a symbol period used to change the phase can be modified with the `DEVIATN.DEVIATION_M` setting. This is equivalent to changing the shaping of the symbol. Setting `DEVIATN.DEVIATION_M=7` will generate a standard shaped MSK signal.

### 24.3 Amplitude Modulation

**CC1100** supports two different forms of amplitude modulation: On-Off Keying (OOK) and Amplitude Shift Keying (ASK). OOK modulation simply turns on or off the PA to modulate 1 and 0 respectively. When using ASK the modulation depth (the difference between 1 and 0) can be programmed, and the power ramping will be shaped. This will produce a more bandwidth constrained output spectrum.

<sup>2</sup> Identical to offset QPSK with half-sine shaping (data coding may differ)

Another use of the preamble quality threshold is as a qualifier for the optional RX termination timer. See section 27.7 on page 33 for details.

The preamble quality estimator increases an internal counter by one each time a bit is received that is different from the previous bit, and decreases the counter by 4 each time a bit is received that is the same as the last bit. The counter saturates at 0 and 31. The threshold is configured with the register field `PKTCTRL1.PQT`. A threshold of `4·PQT` for this counter is used to gate sync word detection.

By setting the value to zero, the preamble quality qualifier of the synch word is disabled.

A “Preamble Quality reached” flag can also be observed on one of the GDO pins and in the status register bit `PKTSTATUS.PQT_REACHED`. This flag asserts when the received signal exceeds the PQT.

## 25.2 RSSI

The RSSI value is an estimate of the signal level in the current channel. This value is based on the current gain setting in the RX chain and the measured signal level in the channel.

In RX mode, the RSSI value can be read continuously from the RSSI status register, until the demodulator detects a sync word (when sync word detection is enabled). At that point, the RSSI readout value is frozen until the next time the chip enters the RX state. The RSSI value is in dB with ½dB resolution.

If `PKTCTRL1.APPEND_STATUS` is enabled, a snapshot of the RSSI during the first 8 bytes of the packet is automatically added to the end of each received packet.

## 25.3 Carrier Sense (CS)

The Carrier Sense flag is used as a sync word qualifier and for CCA. The CS flag can be set based on two conditions, which can be individually adjusted:

- CS is asserted when the RSSI is above a programmable absolute threshold, and de-asserted when RSSI is below the same threshold (with hysteresis).
- CS is asserted when the RSSI has increased with a programmable number of dB from one RSSI sample to the next, and de-asserted when RSSI has decreased with the same number of dB. This setting is not dependent on the absolute signal level and is thus useful to detect signals in environments with time varying noise floor.

Carrier Sense (CS) can be used as a sync word qualifier that requires the signal level to be higher than the threshold for a sync word search to be performed. The signal can also be observed on one of the GDO pins and in the status register bit `PKTSTATUS.CS`.

Other uses of Carrier Sense include the TX-If-CCA function (see section 25.4 on page 28) and the optional fast RX termination (see section 27.7 on page 33).

## 25.4 Clear Channel Assessment (CCA)

The Clear Channel Assessment is used to indicate if the current channel is free or busy. The current CCA state is viewable on any of GDO pins.

`MCSM1.CCA_MODE` selects the mode to use when determining CCA.

When the `STX` or `SFSTXON` command strobe is given while **CC1100** is in the RX state, the TX state is only entered if the clear channel requirements are fulfilled. The chip will otherwise remain in RX. This feature is called TX if CCA.

Four CCA requirements can be programmed:

- Always (CCA disabled, always goes to TX)
- If RSSI is below threshold
- Unless currently receiving a packet
- Both the above (RSSI below threshold and not currently receiving a packet)

## 25.5 Link Quality Indicator (LQI)

The Link Quality Indicator is a metric of the current quality of the received signal. If `PKTCTRL1.APPEND_STATUS` is enabled, the value is automatically appended to the end of each received packet. The value can also be read from the `LQI` status register. The LQI is calculated over the 64 symbols following the sync word (first 8 packet bytes). LQI is best used as a relative measurement of the link quality, since the value is dependent on the modulation format.

## 26 Forward Error Correction with Interleaving

### 26.1 Forward Error Correction (FEC)

**CC1100** has built in support for Forward Error Correction (FEC). To enable this option, set `MDMCFG1.FEC_EN` to 1. FEC is employed on the data field and CRC word in order to reduce the gross bit error rate when operating near the sensitivity limit. Redundancy is added to the transmitted data in such a way that the receiver can restore the original data in the presence of some bit errors.

The use of FEC allows correct reception at a lower SNR, thus extending communication range. Alternatively, for a given SNR, using FEC decreases the bit error rate (BER). As the packet error rate (PER) is related to BER by:

$$PER = 1 - (1 - BER)^{packet\_length}$$

a lower BER can be used to allow significantly longer packets, or a higher percentage of packets of a given length, to be transmitted successfully. Finally, in realistic ISM radio environments, transient and time-varying phenomena will produce occasional errors even in otherwise good reception conditions. FEC will mask such errors and, combined with interleaving of the coded data, even correct relatively long periods of faulty reception (burst errors).

The FEC scheme adopted for **CC1100** is convolutional coding, in which  $n$  bits are generated based on  $k$  input bits and the  $m$  most recent input bits, forming a code stream able to withstand a certain number of bit errors between each coding state (the  $m$ -bit window).

The convolutional coder is a rate 1/2 code with a constraint length of  $m=4$ . The coder codes one input bit and produces two output bits; hence, the effective data rate is halved.

### 26.2 Interleaving

Data received through real radio channels will often experience burst errors due to interference and time-varying signal strengths. In order to increase the robustness to errors spanning multiple bits, interleaving is used when FEC is enabled. After de-interleaving, a continuous span of errors in the received stream will become single errors spread apart.

**CC1100** employs matrix interleaving, which is illustrated in Figure 9. The on-chip interleaving and de-interleaving buffers are 4 x 4 matrices. In the transmitter, the data bits are written into the rows of the matrix, whereas the bit sequence to be transmitted is read from the columns of the matrix and fed to the rate 1/2 convolutional coder. Conversely, in the receiver, the received symbols are written into the columns of the matrix, whereas the data passed onto the convolutional decoder is read from the rows of the matrix.

When FEC and interleaving is used, the amount of data transmitted over the air must be a multiple of the size of the interleaver buffer (two bytes). In addition, at least one extra byte is required for trellis termination. The packet control hardware therefore automatically inserts one or two extra bytes at the end of the packet, so that the total length of the data to be interleaved is an even number. Note that these extra bytes are invisible to the user, as they are removed before the received packet enters the RX FIFO.

Due to the implementation of the FEC and interleaver, the data to be interleaved must be at least two bytes. One byte long fixed length packets without CRC is therefore not supported when FEC/interleaving is enabled.

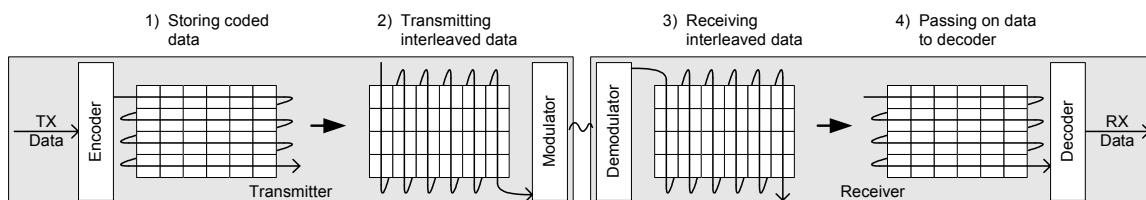

Figure 9: General principle of matrix interleaving

27 Radio Control

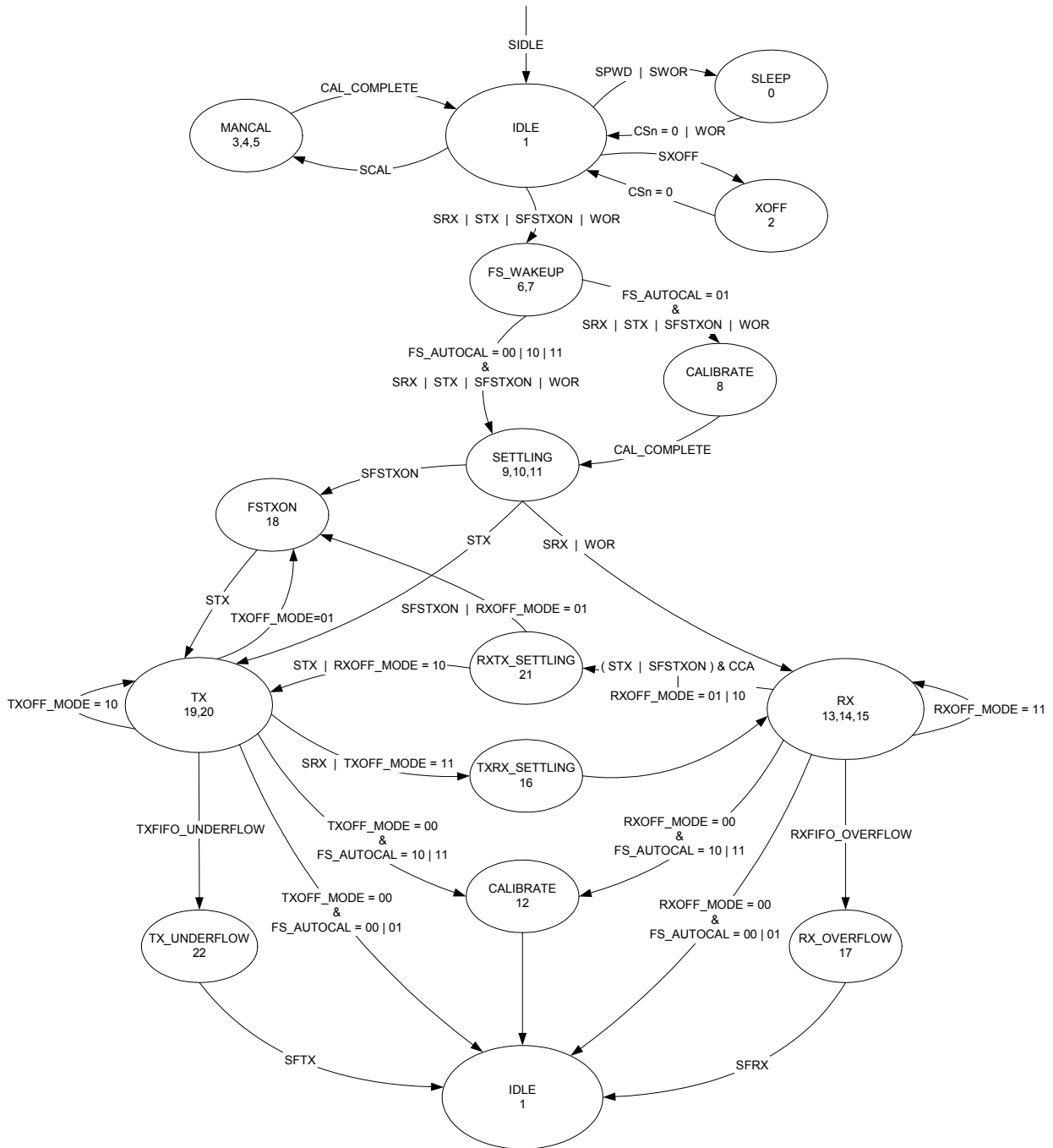

Figure 10: Complete Radio Control State Diagram

CC1100 has a built-in state machine that is used to switch between different operation states (modes). The change of state is done either by using command strobes or by internal events such as TX FIFO underflow.

A simplified state diagram, together with typical usage and current consumption, is

shown in Figure 4 on page 17. The complete radio control state diagram is shown in Figure 10. The numbers refer to the state number readable in the MARCSTATE status register. This functionality is primarily for test purposes.

### 27.1 Power on start-up sequence

When the power supply is turned on, the system must be reset. One of the following two sequences must be followed: Automatic power-on reset or manual reset.

A power-on reset circuit is included in the **CC1100**. The minimum requirements stated in Section 12 must be followed for the power-on reset to function properly. The internal power-up sequence is completed when `CHIP_RDYn` goes low. `CHIP_RDYn` is observed on the `SO` pin after `CSn` is pulled low. See Section 18.1 for more details on `CHIP_RDYn`.

The other global reset possibility on **CC1100** is the `SRES` command strobe. By issuing this strobe, all internal registers and states are set to the default, idle state. The power-up sequence is as follows (see Figure 11):

- Set `SCLK=1` and `SI=0`, to avoid potential problems with pin control mode (see section 19.3 on page 22).
- Strobe `CSn` low / high.
- Hold `CSn` high for at least 40 $\mu$ s.
- Pull `CSn` low and wait for `SO` to go low (`CHIP_RDYn`).
- Issue the `SRES` strobe.
- When `SO` goes low again, reset is complete and the chip is in the IDLE state.

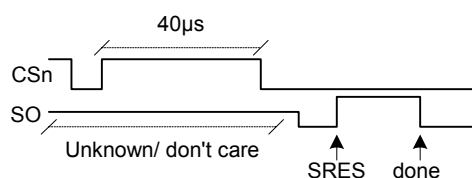

**Figure 11: Power-up with `SRES`**

It is recommended to always send a `SRES` command strobe on the SPI interface after power-on even though power-on reset is used.

### 27.2 Crystal Control

The crystal oscillator (XOSC) is either automatically controlled or always on, if `MCSM0.XOSC_FORCE_ON` is set.

In the automatic mode, the XOSC will be turned off if the `SXOFF` or `SPWD` command strobes are issued; the state machine then goes to `XOFF` or `SLEEP` respectively. This

can be done from any state. The XOSC will be turned off when `CSn` is released (goes high). The XOSC will be automatically turned on again when `CSn` goes low. The state machine will then go to the IDLE state. The `SO` pin on the SPI interface must be zero before the SPI interface is ready to be used; as described in Section 18 on page 18.

If the XOSC is forced on, the crystal will always stay on even in the SLEEP state.

Crystal oscillator start-up time depends on crystal ESR and load capacitances. The electrical specification for the crystal oscillator can be found in section 7 on page 9.

### 27.3 Voltage Regulator Control

The voltage regulator to the digital core is controlled by the radio controller. When the chip enters the SLEEP state, which is the state with the lowest current consumption, this regulator is disabled. This occurs after `CSn` is released when a `SPWD` command strobe has been sent on the SPI interface. The chip is now in the SLEEP state. Setting `CSn` low again will turn on the regulator and crystal oscillator and make the chip enter the IDLE state.

When wake on radio is enabled, the WOR module will control the voltage regulator as described in Section 27.5.

### 27.4 Active Modes

**CC1100** has two active modes: receive and transmit. These modes are activated directly by the MCU by using the `SRX` and `STX` command strobes, or automatically by Wake on Radio.

The frequency synthesizer must be calibrated regularly. **CC1100** has one manual calibration option (using the `SCAL` strobe), and three automatic calibration options, controlled by the `MCSM0.FS_AUTOCAL` setting:

- Calibrate when going from IDLE to either RX or TX (or FSTXON)
- Calibrate when going from either RX or TX to IDLE
- Calibrate every fourth time when going from either RX or TX to IDLE

The calibration takes a constant number of XOSC cycles (see Table 22 for timing details).

When RX is activated, the chip will remain in receive mode until the RX termination timer expires (see section 27.7) or a packet has been successfully received. After one of these events, the radio controller will go to the state indicated by the `MCSM1.RXOFF_MODE` setting. The possible destinations are:

- IDLE
- FSTXON: Frequency synthesizer on and ready at the TX frequency. Activate TX with `STX`.
- TX: Start sending preambles
- RX: Start search for a new packet

Similarly, when TX is active the chip will remain in the TX state until the current packet has been successfully transmitted. Then the state will change as indicated by the `MCSM1.TXOFF_MODE` setting. The possible destinations are the same as for RX.

The MCU can manually change the state from RX to TX and vice versa by using the command strobes. If the radio controller is currently in transmit and the `SRX` strobe is used, the current transmission will be ended and the transition to RX will be done.

If the radio controller is in RX when the `STX` or `SFSTXON` command strobes are used, the “TX if clear channel” function will be used. If the channel is not clear, the chip will remain in RX. The `MCSM1.CCA_MODE` setting controls the conditions for clear channel assessment. See section 25.4 on page 28 for details.

The `SIDLE` command strobe can always be used to force the radio controller to go to the IDLE state.

### 27.5 Wake on Radio (WOR)

The optional Wake on Radio (WOR) functionality enables **CC1100** to periodically wake up from deep sleep and listen for incoming packets without MCU interaction.

When WOR is enabled, the **CC1100** will go to the SLEEP state when `CSn` is released after the `SWOR` command strobe has been sent on the SPI interface. The RC oscillator must be enabled before the WOR strobe can be used, as it is the clock source for the WOR timer. The on-chip timer will get **CC1100** back into the IDLE state when the timer expires. After a programmable time in RX, the chip goes back to SLEEP, unless a packet is received. See

section 27.7 for details on how the timeout works.

**CC1100** can be set up to signal the MCU that a packet has been received by using the GDO pins. If a packet is received, the `MCSM1.RXOFF_MODE` will determine the behaviour at the end of the received packet. When the MCU has read the packet, it can put the chip back into SLEEP with the `SWOR` strobe. The FIFO will lose its contents in the SLEEP state.

The WOR timer has two events, Event 0 and Event 1. In the SLEEP state with WOR activated, reaching Event 0 will turn the digital regulator and start the crystal oscillator. Event 1 follows Event 0 after a programmed timeout.

The time between two consecutive Event 0 is programmed with a mantissa value given by `WOREVT1.EVENT0` and `WOREVT0.EVENT0`, and an exponent value set by `WORCTRL.WOR_RES`. The equation is:

$$t_{Event0} = \frac{750}{f_{XOSC}} \cdot EVENT0 \cdot 2^{5-WOR\_RES}$$

The Event 1 timeout is programmed with `WORCTRL.EVENT1`. Figure 12 shows the timing relationship between Event 0 timeout and Event 1 timeout.

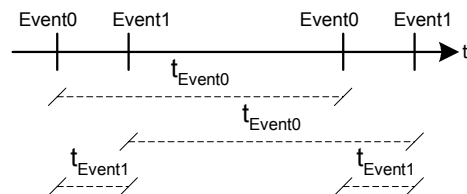

**Figure 12: Event 0 and Event 1 Relationship**

The WOR functionality has two control modes selected by the `PKTCTRL1.WOR_AUTOSYNC` bit. When this value is set to 0, the radio will wake up on Event 0 and enable RX on Event 1. This ensures that RX is entered at a precise time.

When `PKTCTRL1.WOR_AUTOSYNC` is set to 1, after Event 0 wakes up the chip, it will enter RX mode as soon as the chip is ready. When a sync word is detected, the WOR timer will be reset to the programmed Event 1 value. The timer will now be synchronized to the received packet. By programming Event 0 to the packet spacing time and Event 1 to a time large enough to wake up the chip and receive a



sync word, the timer will stay self-synchronized to the incoming packets.

### 27.5.1 RC oscillator and timing

The frequency of the low-power RC oscillator used for the WOR functionality varies with temperature and supply voltage. In order to keep the frequency as accurate as possible, the RC oscillator will be calibrated whenever possible, which is when the XOSC is running and the chip is not in the SLEEP state. When the power and XOSC is enabled, the clock used by the WOR timer is a divided XOSC clock. When the chip goes to the sleep state, the RC oscillator will use the last valid calibration result. The frequency of the RC oscillator is locked to the main crystal frequency divided by 750.

Description	XOSC periods	26MHz crystal
Idle to RX, no calibration	2298	88.4µs
Idle to RX, with calibration	~21037	809µs
Idle to TX/FSTXON, no calibration	2298	88.4µs
Idle to TX/FSTXON, with calibration	~21037	809µs
TX to RX switch	560	21.5µs
RX to TX switch	250	9.6µs
RX or TX to IDLE, no calibration	2	0.1µs
RX or TX to IDLE, with calibration	~18739	721µs
Manual calibration	~18739	721µs

**Table 22: State transition timing**

## 27.6 Timing

The radio controller controls most timing in **CC1100**, such as synthesizer calibration, PLL lock and RT/TX turnaround times. Timing from IDLE to RX and IDLE to TX is constant, dependent on the auto calibration setting. RX/TX and TX/RX turnaround times are constant. The calibration time is constant 18739 clock periods. Table 22 shows timing in crystal clock cycles for key state transitions.

Power on time and XOSC start-up times are variable, but within the limits stated in Table 7.

## 27.7 RX Termination Timer

**CC1100** has optional functions for automatic termination of RX after a programmable time.

The main use for this functionality is wake-on-radio (WOR), but it may be useful for other applications. The termination timer starts when enabling the demodulator. The timeout is programmable with the `MCSM2.RX_TIME` setting. When the timer expires, the radio controller will check the condition for staying in RX; if the condition is not met, RX will terminate. After the timeout, the condition will be checked continuously.

The programmable conditions are:

- `MCSM2.RX_TIME_QUAL=0`: Continue receive if sync word has been found
- `MCSM2.RX_TIME_QUAL=1`: Continue receive if sync word has been found or preamble quality is above threshold (PQT)

If the system can expect the transmission to have started when enabling the receiver, the `MCSM2.RX_TIME_RSSI` function can be used. The radio controller will then terminate RX if the first valid carrier sense sample indicates no carrier (RSSI below threshold). See Section 25.3 on page 28 for details on Carrier Sense.

For ASK/OOK modulation, lack of carrier sense is only considered valid after eight symbol periods. Thus, the `MCSM2.RX_TIME_RSSI` function can be used in ASK/OOK mode when the distance between "1" symbols is 8 or less.

If RX terminates due to no carrier sense when the `MCSM2.RX_TIME_RSSI` function is used, or if no sync word was found when using the `MCSM2.RX_TIME` timeout function, the chip will always go back to IDLE. Otherwise, the `MCSM1.RXOFF_MODE` setting determines the state to go to when RX ends.

Note that in wake-on-radio (WOR) mode, the WOR state is cleared in the latter case. This means that the chip will not automatically go back to SLEEP again, even if e.g. the address field in the packet did not match. It is therefore recommended to always wake up the microcontroller on sync word detection when using WOR mode. This can be done by selecting output signal 6 (see Table 27 on page 39) on one of the programmable GDO output pins, and programming the microcontroller to wake up on an edge-triggered interrupt from this GDO pin.

## 28 Data FIFO

The **CC1100** contains two 64 byte FIFOs, one for received data and one for data to be transmitted. The SPI interface is used to read from the RX FIFO and write to the TX FIFO. Section 18.4 contains details on the SPI FIFO access. The FIFO controller will detect overflow in the RX FIFO and underflow in the TX FIFO.

When writing to the TX FIFO it is the responsibility of the MCU to avoid TX FIFO overflow. This will not be detected by the **CC1100**.

Likewise, when reading the RX FIFO the MCU must avoid reading the RX FIFO past its empty value, since this will lead to an error that is not detected by the **CC1100**.

The chip status byte that is available on the **SO** pin while transferring the SPI address contains the fill grade of the RX FIFO if the address is a read operation and the fill grade of the TX FIFO if the address is a write operation. Section 18.1 on page 18 contains more details on this.

The number of bytes in the RX FIFO and TX FIFO can also be read from the status registers `RXBYTES.NUM_RXBYTES` and `TXBYTES.NUM_TXBYTES` respectively.

The 4-bit `FIFOTHRR.FIFO_THR` setting is used to program threshold points in the FIFOs. Table 23 lists the 16 `FIFO_THR` settings and the corresponding thresholds for the RX and TX FIFOs. The threshold value is coded in opposite directions for the RX FIFO and TX FIFO. This gives equal margin to the overflow and underflow conditions when the threshold is reached.

A flag will assert when the number of bytes in the FIFO is equal to or higher than the programmed threshold. The flag is used to generate the FIFO status signals that can be viewed on the GDO pins (see Section 35 on page 38).

Figure 14 shows the number of bytes in both the RX FIFO and TX FIFO when the threshold flag toggles, in the case of `FIFO_THR=13`. Figure 13 shows the flag as the respective FIFO is filled above the threshold, and then drained below.

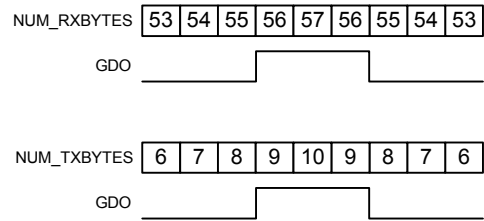

**Figure 13: FIFO\_THR=13 vs. number of bytes in FIFO**

FIFO_THR	Bytes in TX FIFO	Bytes in RX FIFO
0 (0000)	61	4
1 (0001)	57	8
2 (0010)	53	12
3 (0011)	49	16
4 (0100)	45	20
5 (0101)	41	24
6 (0110)	37	28
7 (0111)	33	32
8 (1000)	29	36
9 (1001)	25	40
10 (1010)	21	44
11 (1011)	17	48
12 (1100)	13	52
13 (1101)	9	56
14 (1110)	5	60
15 (1111)	1	64

**Table 23: FIFO\_THR settings and the corresponding FIFO thresholds**

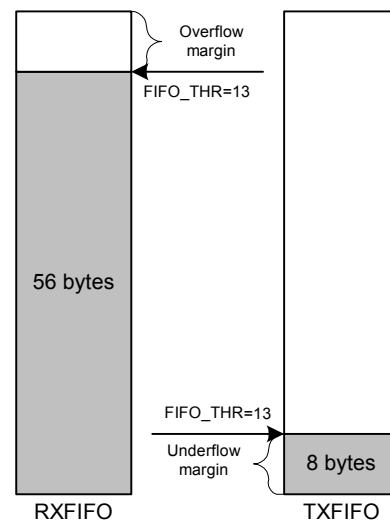

**Figure 14: Example of FIFOs at threshold**

## 29 Frequency Programming

The frequency programming in **CC1100** is designed to minimize the programming needed in a channel-oriented system.

To set up a system with channel numbers, the desired channel spacing is programmed with the `MDMCFG0.CHANSPC_M` and `MDMCFG1.CHANSPC_E` registers. The channel spacing registers are mantissa and exponent respectively.

$$f_{carrier} = \frac{f_{XOSC}}{2^{16}} \cdot (FREQ + CHAN \cdot (256 + CHANSPC\_M \cdot 2^{CHANSPC\_E-2}))$$

The preferred IF frequency is programmed with the `FSCTRL1.FREQ_IF` register. The IF frequency is given by:

$$f_{IF} = \frac{f_{XOSC}}{2^{10}} \cdot FREQ\_IF$$

Note that the SmartRF® Studio software automatically calculates the optimum `FSCTRL1.FREQ_IF` register setting based on channel spacing and channel filter bandwidth.

## 30 VCO

The VCO is completely integrated on-chip.

### 30.1 VCO and PLL Self-Calibration

The VCO characteristics will vary with temperature and supply voltage changes, as well as the desired operating frequency. In order to ensure reliable operation, **CC1100** includes frequency synthesizer self-calibration circuitry. This calibration should be done regularly, and must be performed after turning on power and before using a new frequency (or channel). The number of XOSC cycles for completing the PLL calibration is given in Table 22 on page 33.

## 31 Voltage Regulators

**CC1100** contains several on-chip linear voltage regulators, which generate the supply voltage needed by low-voltage modules. These voltage regulators are invisible to the user, and

The base or start frequency is set by the 24 bit frequency word located in the `FREQ2`, `FREQ1` and `FREQ0` registers. This word will typically be set to the centre of the lowest channel frequency that is to be used.

The desired channel number is programmed with the 8-bit channel number register, `CHANNR.CHAN`, which is multiplied by the channel offset. The resultant carrier frequency is given by:

If any frequency programming register is altered when the frequency synthesizer is running, the synthesizer may give an undesired response. Hence, the frequency programming should only be updated when the radio is in the IDLE state.

The calibration can be initiated automatically or manually. The synthesizer can be automatically calibrated each time the synthesizer is turned on, or each time the synthesizer is turned off. This is configured with the `MCSM0.FS_AUTOCAL` register setting. In manual mode, the calibration is initiated when the `SCAL` command strobe is activated in the IDLE mode. The default setting is to calibrate each time the frequency synthesizer is turned on.

Note that the calibration values are maintained in sleep mode, so the calibration is still valid after waking up from sleep mode (unless supply voltage or temperature has changed significantly).

can be viewed as integral parts of the various modules. The user must however make sure that the absolute maximum ratings and required pin voltages in Table 1 and Table 13

are not exceeded. The voltage regulator for the digital core requires one external decoupling capacitor.

Setting the CS<sub>n</sub> pin low turns on the voltage regulator to the digital core and starts the crystal oscillator. The SO pin on the SPI interface must go low before using the serial interface (setup time is TBD).

On initial power up, the MCU must set CS<sub>n</sub> low and issue the reset command strobe SRES.

If the chip is programmed to enter power-down mode, (SPWD strobe issued), the power will be turned off after CS<sub>n</sub> goes high. The power and crystal oscillator will be turned on again when CS<sub>n</sub> goes low.

The voltage regulator output should only be used for driving the **CC1100**.

### 32 Output Power Programming

The RF output power level from the device has two levels of programmability, as illustrated in Figure 15. Firstly, the special PATABLE register can hold up to eight user selected output power settings. Secondly, the 3-bit FRENDO.PA\_POWER value selects the PATABLE entry to use. This two-level functionality provides flexible PA power ramp up and ramp down at the start and end of transmission, as well as ASK modulation shaping. In each case, all the PA power settings in the PATABLE from index 0 up to the FRENDO.PA\_POWER value are used.

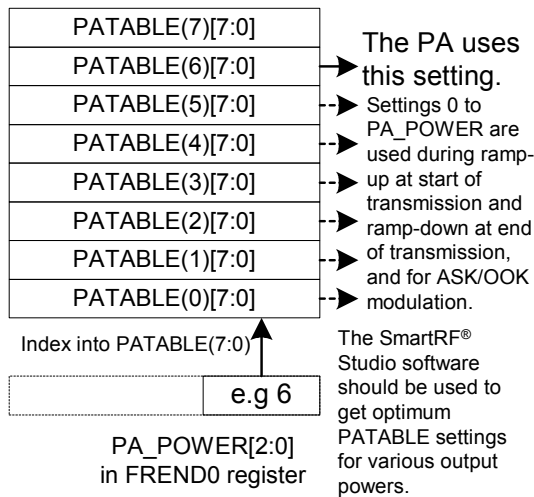

**Figure 15: PA\_POWER and PATABLE**

The power ramping at the start and at the end of a packet can be turned off by setting FRENDO.PA\_POWER to zero and then programming the desired output power to index zero in the PATABLE.

Table 24 contains recommended PATABLE settings for various output levels and frequency bands. See section 18.5 on page 19 for PATABLE programming details.

Table 25 contains output power and current consumption for default PATABLE setting (0xC6).

With ASK modulation, the eight power settings are used for shaping. The modulator contains a counter that counts up when transmitting a one and down when transmitting a zero. The counter counts at a rate equal to 8 times the symbol rate. The counter saturates at FRENDO.PA\_POWER and 0 respectively. This counter value is used as an index for a lookup in the power table. Thus, in order to utilize the whole table, FRENDO.PA\_POWER should be 7 when ASK is active. The shaping of the ASK signal is dependent on the configuration of the PATABLE.

Output power [dBm]	315MHz		433MHz		868MHz		915MHz	
	Setting	Current consumption, typ. [mA]	Setting	Current consumption, typ. [mA]	Setting	Current consumption, typ. [mA]	Setting	Current consumption, typ. [mA]
-30	0x04	10.9	0x68	11.7	0x03	12.0	0x11	11.9
-20	0x17	11.5	0x6C	12.2	0x0D	12.6	0x0B	12.4
-15	0x1D	12.2	0x1C	12.8	0x1C	13.2	0x1B	13.1
-10	0x26	13.4	0x06	14.3	0x34	14.6	0x6D	13.7
-5	0x69	13.0	0x3A	13.8	0x67	14.4	0x67	14.2
0	0x51	15.1	0x51	16.1	0x60	16.8	0x50	16.5
5	0x86	18.3	0x85	19.3	0x85	19.9	0x85	19.3
7	0xCC	22.2	0xC8	24.0	0xCC	25.6	0xC9	25.6
10	0xC3	26.9	0xC0	28.8	0xC3	30.3	0xC1	30.2

Table 24: Optimum PATABLE settings for various output power levels and frequency bands

Default power setting	315MHz		433MHz		868MHz		915MHz	
	Output power [dBm]	Current consumption, typ. [mA]	Output power [dBm]	Current consumption, typ. [mA]	Output power [dBm]	Current consumption, typ. [mA]	Output power [dBm]	Current consumption, typ. [mA]
0xC6	8.9	25.1	7.8	25.0	8.9	28.3	8.1	26.8

Table 25: Output power and current consumption for default PATABLE setting

### 33 Crystal Oscillator

A crystal in the frequency range 26MHz-27MHz must be connected between the XOSC\_Q1 and XOSC\_Q2 pins. The oscillator is designed for parallel mode operation of the crystal. In addition, loading capacitors (C81 and C101) for the crystal are required. The loading capacitor values depend on the total load capacitance,  $C_L$ , specified for the crystal. The total load capacitance seen between the crystal terminals should equal  $C_L$  for the crystal to oscillate at the specified frequency.

$$C_L = \frac{1}{\frac{1}{C_{81}} + \frac{1}{C_{101}}} + C_{parasitic}$$

The parasitic capacitance is constituted by pin input capacitance and PCB stray capacitance. Total parasitic capacitance is typically 2.5pF.

The crystal oscillator circuit is shown in Figure 16. Typical component values for different values of  $C_L$  are given in Table 26.

The crystal oscillator is amplitude regulated. This means that a high current is used to start up the oscillations. When the amplitude builds up, the current is reduced to what is necessary to maintain approximately 0.4Vpp signal swing. This ensures a fast start-up, and keeps the drive level to a minimum. The ESR of the crystal should be within the specification in order to ensure a reliable start-up (see section 7 on page 9).

The initial tolerance, temperature drift, aging and load pulling should be carefully specified in order to meet the required frequency accuracy in a certain application. By specifying the *total* expected frequency accuracy in SmartRF® Studio together with data rate and frequency deviation, the software calculates the total bandwidth and compares this to the chosen receiver channel filter bandwidth. The software reports any contradictions, and a more accurate crystal is recommended if required.

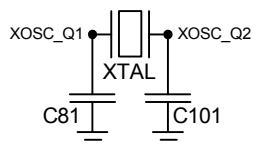

Figure 16: Crystal oscillator circuit

Component	$C_L=10\text{pF}$	$C_L=13\text{pF}$	$C_L=16\text{pF}$
C81	15pF	22pF	27pF
C101	15pF	22pF	27pF

Table 26: Crystal oscillator component values

### 34 Antenna Interface

The balanced RF input and output of **CC1100** share two common pins and are designed for a simple, low-cost matching and balun network on the printed circuit board. The receive- and transmit switching at the **CC1100** front-end is controlled by a dedicated on-chip function, eliminating the need for an external RX/TX-switch.

A few passive external components combined with the internal RX/TX switch/termination circuitry ensures match in both RX and TX mode.

Although **CC1100** has a balanced RF input/output, the chip can be connected to a single-ended antenna with few external low cost capacitors and inductors.

### 35 General Purpose / Test Output Control Pins

The three digital output pins `GDO0`, `GDO1` and `GDO2` are general control pins configured with `IOCFG0.GDO0_CFG`, `IOCFG1.GDO1_CFG` and `IOCFG2.GDO3_CFG` respectively. Table 27 shows the different signals that can be monitored on the GDO pins. These signals can be used as an interrupt to the MCU. `GDO1` is the same pin as the `SO` pin on the SPI interface, thus the output programmed on this pin will only be valid when `CSn` is high. The default value for `GDO1` is 3-stated, which is useful when the SPI interface is shared with other devices.

the MCU is up and running, it can change the clock frequency by writing to `IOCFG0.GDO0_CFG`. This will not produce any clock glitches.

An on-chip analog temperature sensor is enabled by writing the value 128 (0x80h) to the `IOCFG0.GDO0_CFG` register. The voltage on the `GDO0` pin is then proportional to temperature. See section 10 on page 11 for temperature sensor specifications.

The default value for `GDO0` is a 125kHz-146kHz clock output (XOSC frequency divided by 192). Since the XOSC is turned on at power-on-reset, this can be used to clock the MCU in systems with only one crystal. When

GDO0_CFG[5:0] GDO1_CFG[5:0] GDO2_CFG[5:0]	Description
0 (0x00)	Associated to the RX FIFO: Asserts when RX FIFO is filled above RXFIFO_THR. De-asserts when RX FIFO is drained below RXFIFO_THR.
1 (0x01)	Associated to the RX FIFO: Asserts when RX FIFO is filled above RXFIFO_THR or the end of packet is reached. De-asserts when RX FIFO is empty.
2 (0x02)	Associated to the TX FIFO: Asserts when the TX FIFO is filled above TXFIFO_THR. De-asserts when the TX FIFO is below TXFIFO_THR.
3 (0x03)	Associated to the TX FIFO: Asserts when TX FIFO is full. De-asserts when the TX FIFO is drained below TXFIFO_THR.
4 (0x04)	Asserts when the RX FIFO has overflowed. De-asserts when the FIFO has been flushed.
5 (0x05)	Asserts when the TX FIFO has underflowed. De-asserts when the FIFO is flushed.
6 (0x06)	Asserts when sync word has been sent / received, and de-asserts at the end of the packet. In RX, the pin will de-assert when the optional address check fails or the RX FIFO overflows. In TX the pin will de-assert if the TX FIFO underflows.
7 (0x07)	Asserts when a packet has been received with OK CRC. De-asserts when the first byte is read from the RX FIFO.
8 (0x08)	Preamble Quality Reached. Asserts when the PQI is above the programmed PQT value.
9 (0x09)	Clear channel assessment. High when RSSI level is below threshold (dependent on the current CCA_MODE setting)
10 (0x0A)	Lock detector output
11 (0x0B)	Serial Clock. Synchronous to the data in synchronous serial mode. Data is set up on the falling edge and is read on the rising edge of SERIAL_CLK.
12 (0x0C)	Serial Synchronous Data Output. Used for synchronous serial mode. The MCU must read DO on the rising edge of SERIAL_CLK. Data is set up on the falling edge by <b>CC1100</b> .
13 (0x0D)	Serial transparent Data Output. Used for asynchronous serial mode.
14 (0x0E)	Carrier sense. High if RSSI level is above threshold.
15 (0x0F)	CRC OK. The last CRC comparison matched. Cleared when entering/restarting RX mode.
16 (0x10)	Reserved – used for test.
17 (0x11)	Reserved – used for test.
18 (0x12)	Reserved – used for test.
19 (0x13)	Reserved – used for test.
20 (0x14)	Reserved – used for test.
21 (0x15)	Reserved – used for test.
22 (0x16)	RX_HARD_DATA[1]. Can be used together with RX_SYMBOL_TICK for alternative serial RX output.
23 (0x17)	RX_HARD_DATA[0]. Can be used together with RX_SYMBOL_TICK for alternative serial RX output.
24 (0x18)	Reserved – used for test.
25 (0x19)	Reserved – used for test.
26 (0x1A)	Reserved – used for test.
27 (0x1B)	PA_PD. PA is enabled when 1, in power-down when 0. Can be used to control external PA or RX/TX switch.
28 (0x1C)	LNA_PD. LNA is enabled when 1, in power-down when 0. Can be used to control external LNA or RX/TX switch.
29 (0x1D)	RX_SYMBOL_TICK. Can be used together with RX_HARD_DATA for alternative serial RX output.
30 (0x1E)	Reserved – used for test.
31 (0x1F)	Reserved – used for test.
32 (0x20)	Reserved – used for test.
33 (0x21)	Reserved – used for test.
34 (0x22)	Reserved – used for test.
35 (0x23)	Reserved – used for test.
36 (0x24)	Reserved – used for test.
37 (0x25)	Reserved – used for test.
38 (0x26)	Reserved – used for test.
39 (0x27)	Reserved – used for test.
40 (0x28)	Reserved – used for test.
41 (0x29)	CHIP_RDY
42 (0x2A)	Reserved – used for test.
43 (0x2B)	XOSC_STABLE
44 (0x2C)	Reserved – used for test.
45 (0x2D)	GDO0_Z_EN_N. When this output is 0, GDO0 is configured as input (for serial TX data).
46 (0x2E)	High impedance (3-state)
47 (0x2F)	HW to 0 (HW1 achieved with_INV signal)
48 (0x30)	CLK_XOSC/1
49 (0x31)	CLK_XOSC/1.5
50 (0x32)	CLK_XOSC/2
51 (0x33)	CLK_XOSC/3
52 (0x34)	CLK_XOSC/4
53 (0x35)	CLK_XOSC/6
54 (0x36)	CLK_XOSC/8
55 (0x37)	CLK_XOSC/12
56 (0x38)	CLK_XOSC/16
57 (0x39)	CLK_XOSC/24
58 (0x3A)	CLK_XOSC/32
59 (0x3B)	CLK_XOSC/48
60 (0x3C)	CLK_XOSC/64
61 (0x3D)	CLK_XOSC/96
62 (0x3E)	CLK_XOSC/128
63 (0x3F)	CLK_XOSC/192

**Table 27: GDO signal selection**

## 36 Asynchronous and Synchronous Serial Operation

Several features and modes of operation have been included in the **CC1100** to provide backward compatibility with previous Chipcon products and other existing RF communication systems. For new systems, it is recommended to use the built-in packet handling features, as they can give more robust communication, significantly offload the microcontroller and simplify software development.

### 36.1 Asynchronous operation

For backward compatibility with systems already using the asynchronous data transfer from other Chipcon products, asynchronous transfer is also included in **CC1100**. When asynchronous transfer is enabled, several of the support mechanisms for the MCU that are included in **CC1100** will be disabled, such as packet handling hardware, buffering in the FIFO and so on. The asynchronous transfer mode does not allow the use of the data whitener, interleaver and FEC.

Only 2-FSK, GFSK and ASK/OOK are supported for asynchronous transfer.

Setting `PKTCTRL0.PKT_FORMAT` to 3 enables asynchronous transparent (serial) mode.

In TX, the `GDO0` pin is used for data input (TX data). Data output can be `GDO0`, `GDO1` or `GDO2`.

The MCU must control start and stop of transmit and receive with the `STX`, `SRX` and `SIDLE` strobes.

## 37 Configuration Registers

The configuration of **CC1100** is done by programming 8-bit registers. The configuration data based on selected system parameters are most easily found by using the SmartRF® Studio software. Complete descriptions of the registers are given in the following tables. After chip reset, all the registers have default values as shown in the tables.

There are 14 Command Strobe Registers, listed in Table 28. Accessing these registers will initiate the change of an internal state or mode. There are 47 normal 8-bit Configuration Registers, listed in Table 29. Many of these

The **CC1100** modulator samples the level of the asynchronous input 8 times faster than the programmed data rate. The timing requirement for the asynchronous stream is that the error in the bit period must be less than one eighth of the programmed data rate.

### 36.2 Synchronous serial operation

In the Synchronous serial operation mode, data is transferred on a two wire serial interface. The **CC1100** provides a clock that is used to set up new data on the data input line or sample data on the data output line. Data input (TX data) is the `GDO0` pin. This pin will automatically be configured as an input when TX is active. The data output pin can be any of the `GDO` pins; this is set by the `IOCFG0.GDO0_CFG`, `IOCFG1.GDO1_CFG` and `IOCFG2.GDO2_CFG` fields.

Preamble and sync word insertion/detection may or may not be active, dependent on the sync mode set by the `MDMCFG3.SYNC_MODE`. If preamble and sync word is disabled, all other packet handler features and FEC should also be disabled. The MCU must then handle preamble and sync word insertion and detection in software. If preamble and sync word insertion/detection is left on, all packet handling features and FEC can be used. The **CC1100** will insert and detect the preamble and sync word and the MCU will only provide/get the data payload. This is equivalent to the recommended FIFO operation mode.

registers are for test purposes only, and need not be written for normal operation of **CC1100**.

There are also 12 Status registers, which are listed in Table 30. These registers, which are read-only, contain information about the status of **CC1100**.

The two FIFOs are accessed through one 8-bit register. Write operations write to the TX FIFO, while read operations read from the RX FIFO.

During the address transfer and while writing to a register or the TX FIFO, a status byte is returned. This status byte is described in Table 17 on page 21.



Table 31 summarizes the SPI address space. The address to use is given by adding the base address to the left and the burst and

read/write bits on the top. Note that the burst bit has different meaning for base addresses above and below 0x2F.

Address	Strobe Name	Description
0x30	SRES	Reset chip.
0x31	SFSTXON	Enable and calibrate frequency synthesizer (if <code>MCSM0.FS_AUTOCAL=1</code> ). If in RX (with CCA): Go to a wait state where only the synthesizer is running (for quick RX / TX turnaround).
0x32	SXOFF	Turn off crystal oscillator.
0x33	SCAL	Calibrate frequency synthesizer and turn it off (enables quick start). SCAL can be strobed from IDLE mode without setting manual calibration mode ( <code>MCSM0.FS_AUTOCAL=0</code> )
0x34	SRX	Enable RX. Perform calibration first if coming from IDLE and <code>MCSM0.FS_AUTOCAL=1</code> .
0x35	STX	In IDLE state: Enable TX. Perform calibration first if <code>MCSM0.FS_AUTOCAL=1</code> . If in RX state and CCA is enabled: Only go to TX if channel is clear.
0x36	SIDLE	Exit RX / TX, turn off frequency synthesizer and exit Wake-On-Radio mode if applicable.
0x37	SAFC	Perform AFC adjustment of the frequency synthesizer as outlined in section 22.1.
0x38	SWOR	Start automatic RX polling sequence (Wake-on-Radio) as described in section 27.5.
0x39	SPWD	Enter power down mode when <code>CSn</code> goes high.
0x3A	SFRX	Flush the RX FIFO buffer.
0x3B	SFTX	Flush the TX FIFO buffer.
0x3C	SWORRST	Reset real time clock.
0x3D	SNOP	No operation. May be used to pad strobe commands to two bytes for simpler software.

**Table 28: Command Strobes**

Address	Register	Description	Preserved in SLEEP state	Details on page number
0x00	IOCFG2	GDO2 output pin configuration	Yes	45
0x01	IOCFG1	GDO1 output pin configuration	Yes	45
0x02	IOCFG0	GDO0 output pin configuration	Yes	45
0x03	FIFOTHR	RX FIFO and TX FIFO thresholds	Yes	46
0x04	SYNC1	Sync word, high byte	Yes	46
0x05	SYNC0	Sync word, low byte	Yes	46
0x06	PKTLEN	Packet length	Yes	46
0x07	PKTCTRL1	Packet automation control	Yes	47
0x08	PKTCTRL0	Packet automation control	Yes	48
0x09	ADDR	Device address	Yes	48
0x0A	CHANNR	Channel number	Yes	48
0x0B	FSCTRL1	Frequency synthesizer control	Yes	49
0x0C	FSCTRL0	Frequency synthesizer control	Yes	49
0x0D	FREQ2	Frequency control word, high byte	Yes	49
0x0E	FREQ1	Frequency control word, middle byte	Yes	50
0x0F	FREQ0	Frequency control word, low byte	Yes	50
0x10	MDMCFG4	Modem configuration	Yes	50
0x11	MDMCFG3	Modem configuration	Yes	50
0x12	MDMCFG2	Modem configuration	Yes	51
0x13	MDMCFG1	Modem configuration	Yes	52
0x14	MDMCFG0	Modem configuration	Yes	52
0x15	DEVIATN	Modem deviation setting	Yes	52
0x16	MCSM2	Main Radio Control State Machine configuration	Yes	53
0x17	MCSM1	Main Radio Control State Machine configuration	Yes	54
0x18	MCSM0	Main Radio Control State Machine configuration	Yes	55
0x19	FOCCFG	Frequency Offset Compensation configuration	Yes	55
0x1A	BSCFG	Bit Synchronization configuration	Yes	55
0x1B	AGCTRL2	AGC control	Yes	55
0x1C	AGCTRL1	AGC control	Yes	56
0x1D	AGCTRL0	AGC control	Yes	56
0x1E	WOREVT1	High byte Event 0 timeout	Yes	56
0x1F	WOREVT0	Low byte Event 0 timeout	Yes	56
0x20	WORCTRL	Wake On Radio control	Yes	57
0x21	FREND1	Front end RX configuration	Yes	57
0x22	FREND0	Front end TX configuration	Yes	58
0x23	FSCAL3	Frequency synthesizer calibration	Yes	58
0x24	FSCAL2	Frequency synthesizer calibration	Yes	58
0x25	FSCAL1	Frequency synthesizer calibration	Yes	58
0x26	FSCAL0	Frequency synthesizer calibration	Yes	59
0x27	RCCTRL1	RC oscillator configuration	Yes	59
0x28	RCCTRL0	RC oscillator configuration	Yes	59
0x29	FSTEST	Frequency synthesizer calibration control	No	59
0x2A	PTEST	Production test	No	59
0x2B	AGCTEST	AGC test	No	59
0x2C	TEST2	Various test settings	No	60
0x2D	TEST1	Various test settings	No	60
0x2E	TEST0	Various test settings	No	60

**Table 29: Configuration Registers Overview**

Address	Register	Description	Details on page number
0x30 (0xF0)	PARTNUM	Part number for <b>CC1100</b>	60
0x31 (0xF1)	VERSION	Current version number	60
0x32 (0xF2)	FREQEST	Frequency Offset Estimate	60
0x33 (0xF3)	LQI	Demodulator estimate for Link Quality	60
0x34 (0xF4)	RSSI	Received signal strength indication	61
0x35 (0xF5)	MARCSTATE	Control state machine state	61
0x36 (0xF6)	WORTIME1	High byte of WOR timer	61
0x37 (0xF7)	WORTIME0	Low byte of WOR timer	62
0x38 (0xF8)	PKTSTATUS	Current GDOx status and packet status	62
0x39 (0xF9)	VCO_VC_DAC	Current setting from PLL calibration module	62
0x3A (0xFA)	TXBYTES	Underflow and number of bytes in the TX FIFO	62
0x3B (0xFB)	RXBYTES	Overflow and number of bytes in the RX FIFO	62

**Table 30: Status Registers Overview**

	Write		Read		
	Single byte	Burst	Single byte	Burst	
	+0x00	+0x40	+0x80	+0xC0	
0x00			IOCFG2		R/W configuration registers, burst access possible
0x01			IOCFG1		
0x02			IOCFG0		
0x03			FIFOTHR		
0x04			SYNC1		
0x05			SYNC0		
0x06			PKTLEN		
0x07			PKTCTRL1		
0x08			PKTCTRL0		
0x09			ADDR		
0x0A			CHANNR		
0x0B			FSCTRL1		
0x0C			FSCTRL0		
0x0D			FREQ2		
0x0E			FREQ1		
0x0F			FREQ0		
0x10			MDMCFG4		
0x11			MDMCFG3		
0x12			MDMCFG2		
0x13			MDMCFG1		
0x14			MDMCFG0		
0x15			DEVIATN		
0x16			MCSM2		
0x17			MCSM1		
0x18			MCSM0		
0x19			FOCCFG		
0x1A			BSCFG		
0x1B			AGCCTRL2		
0x1C			AGCCTRL1		
0x1D			AGCCTRL0		
0x1E			WOREVT1		
0x1F			WOREVT0		
0x20			WORCTRL		
0x21			FREND1		
0x22			FREND0		
0x23			FSCAL3		
0x24			FSCAL2		
0x25			FSCAL1		
0x26			FSCAL0		
0x27			RCCTRL1		
0x28			RCCTRL0		
0x29			FSTEST		
0x2A			PTEST		
0x2B			AGCTEST		
0x2C			TEST2		
0x2D			TEST1		
0x2E			TEST0		
0x2F					
0x30	SRES		SRES	PARTNUM	Command Strobes, Status registers (read only) and multi byte registers
0x31	SFSTXON		SFSTXON	VERSION	
0x32	SXOFF		SXOFF	FREQEST	
0x33	SCAL		SCAL	LQI	
0x34	SRX		SRX	RSSI	
0x35	STX		STX	MARCSTATE	
0x36	SIDLE		SIDLE	WORTIME1	
0x37	SAFC		SAFC	WORTIME0	
0x38	SWOR		SWOR	PKTSTATUS	
0x39	SPWD		SPWD	VCO_VC_DAC	
0x3A	SFRX		SFRX	TXBYTES	
0x3B	SFTX		SFTX	RXBYTES	
0x3C	SWORRST		SWORRST		
0x3D	SNOP		SNOP		
0x3E	PATABLE	PATABLE	PATABLE	PATABLE	
0x3F	TX FIFO	TX FIFO	RX FIFO	RX FIFO	

Table 31: SPI Address Space

### 37.1 Configuration Register Details – Registers with preserved values in sleep state

#### 0x00: IOCFG2 – GDO2 output pin configuration

Bit	Field Name	Reset	R/W	Description
7	Reserved		R0	
6	GDO2_INV	0	R/W	Invert output, i.e. select active low / high
5:0	GDO2_CFG[5:0]	41 (0x29)	R/W	Default is CHP_RDY (See Table 27 on page 39). Should be set to 3-state for lowest power down current.

#### 0x01: IOCFG1 – GDO1 output pin configuration

Bit	Field Name	Reset	R/W	Description
7	GDO_DS	0	R/W	Set high (1) or low (0) output drive strength on the GDO pins.
6	GDO1_INV	0	R/W	Invert output, i.e. select active low / high
5:0	GDO1_CFG[5:0]	46 (0x2E)	R/W	Default is 3-state (See Table 27 on page 39)

#### 0x02: IOCFG0 – GDO0 output pin configuration

Bit	Field Name	Reset	R/W	Description
7	TEMP_SENSOR_ENABLE	0	R/W	Enable analog temperature sensor. Write 0 in all other register bits when using temperature sensor.
6	GDO0_INV	0	R/W	Invert output, i.e. select active low / high
5:0	GDO0_CFG[5:0]	63 (0x3F)	R/W	Default is CLK_XOSC/192 (See Table 27 on page 39). Should be set to 3-state for lowest power down current.

**0x03: FIFOTHR – RX FIFO and TX FIFO thresholds**

Bit	Field Name	Reset	R/W	Description																																																			
7:3	Reserved	0	R/W	Write 0 for compatibility with possible future extensions																																																			
3:0	FIFO_THR[3:0]	7 (0111)	R/W	Set the threshold for the TX FIFO and RX FIFO. The threshold is exceeded when the number of bytes in the FIFO is equal to or higher than the threshold value. <table border="1" style="margin-left: 20px;"> <thead> <tr> <th>Setting</th> <th>Bytes in TX FIFO</th> <th>Bytes in RX FIFO</th> </tr> </thead> <tbody> <tr><td>0 (0000)</td><td>61</td><td>4</td></tr> <tr><td>1 (0001)</td><td>57</td><td>8</td></tr> <tr><td>2 (0010)</td><td>53</td><td>12</td></tr> <tr><td>3 (0011)</td><td>49</td><td>16</td></tr> <tr><td>4 (0100)</td><td>45</td><td>20</td></tr> <tr><td>5 (0101)</td><td>41</td><td>24</td></tr> <tr><td>6 (0110)</td><td>37</td><td>28</td></tr> <tr><td>7 (0111)</td><td>33</td><td>32</td></tr> <tr><td>8 (1000)</td><td>29</td><td>36</td></tr> <tr><td>9 (1001)</td><td>25</td><td>40</td></tr> <tr><td>10 (1010)</td><td>21</td><td>44</td></tr> <tr><td>11 (1011)</td><td>17</td><td>48</td></tr> <tr><td>12 (1100)</td><td>13</td><td>52</td></tr> <tr><td>13 (1101)</td><td>9</td><td>56</td></tr> <tr><td>14 (1110)</td><td>5</td><td>60</td></tr> <tr><td>15 (1111)</td><td>1</td><td>64</td></tr> </tbody> </table>	Setting	Bytes in TX FIFO	Bytes in RX FIFO	0 (0000)	61	4	1 (0001)	57	8	2 (0010)	53	12	3 (0011)	49	16	4 (0100)	45	20	5 (0101)	41	24	6 (0110)	37	28	7 (0111)	33	32	8 (1000)	29	36	9 (1001)	25	40	10 (1010)	21	44	11 (1011)	17	48	12 (1100)	13	52	13 (1101)	9	56	14 (1110)	5	60	15 (1111)	1	64
Setting	Bytes in TX FIFO	Bytes in RX FIFO																																																					
0 (0000)	61	4																																																					
1 (0001)	57	8																																																					
2 (0010)	53	12																																																					
3 (0011)	49	16																																																					
4 (0100)	45	20																																																					
5 (0101)	41	24																																																					
6 (0110)	37	28																																																					
7 (0111)	33	32																																																					
8 (1000)	29	36																																																					
9 (1001)	25	40																																																					
10 (1010)	21	44																																																					
11 (1011)	17	48																																																					
12 (1100)	13	52																																																					
13 (1101)	9	56																																																					
14 (1110)	5	60																																																					
15 (1111)	1	64																																																					

**0x04: SYNC1 – Sync word, high byte**

Bit	Field Name	Reset	R/W	Description
7:0	SYNC[15:8]	211 (0xD3)	R/W	8 MSB of 16-bit sync word

**0x05: SYNC0 – Sync word, low byte**

Bit	Field Name	Reset	R/W	Description
7:0	SYNC[7:0]	145 (0x91)	R/W	8 LSB of 16-bit sync word

**0x06: PKTLEN – Packet length**

Bit	Field Name	Reset	R/W	Description
7:0	PACKET_LENGTH	255 (0xFF)	R/W	Indicates the packet length when fixed length packets are enabled. If variable length packets are used, this value indicates the maximum length packets allowed.

**0x07: PKTCTRL1 – Packet automation control**

Bit	Field Name	Reset	R/W	Description										
7:5	PQT[2:0]	0 (000)	R/W	<p>Preamble quality estimator threshold. The preamble quality estimator increases an internal counter by one each time a bit is received that is different from the previous bit, and decreases the counter by 4 each time a bit is received that is the same as the last bit. The counter saturates at 0 and 31.</p> <p>A threshold of 4·PQT for this counter is used to gate sync word detection. When PQT=0 a sync word is always accepted.</p>										
4	WOR_AUTOSYNC	0	R/W	Automatically synchronize timer to received packet in wake on radio mode. When enabled the timer will automatically reset the WOR timer when a sync word is detected.										
3	Reserved	0	R/W	Write 0 for compatibility with possible future extensions										
2	APPEND_STATUS	1	R/W	When enabled, two status bytes will be appended to the payload of the packet. The status bytes contain RSSI and LQI values, as well as the CRC OK flag.										
1:0	ADR_CHK[1:0]	0 (00)	R/W	<p>Controls address check configuration of received packages.</p> <table border="1"> <thead> <tr> <th>Setting</th> <th>Address check configuration</th> </tr> </thead> <tbody> <tr> <td>0 (00)</td> <td>No address check</td> </tr> <tr> <td>1 (01)</td> <td>Address check, no broadcast</td> </tr> <tr> <td>2 (10)</td> <td>Address check, 0 (0x00) broadcast</td> </tr> <tr> <td>3 (11)</td> <td>Address check, 0 (0x00) and 255 (0xFF) broadcast</td> </tr> </tbody> </table>	Setting	Address check configuration	0 (00)	No address check	1 (01)	Address check, no broadcast	2 (10)	Address check, 0 (0x00) broadcast	3 (11)	Address check, 0 (0x00) and 255 (0xFF) broadcast
Setting	Address check configuration													
0 (00)	No address check													
1 (01)	Address check, no broadcast													
2 (10)	Address check, 0 (0x00) broadcast													
3 (11)	Address check, 0 (0x00) and 255 (0xFF) broadcast													

**0x08: PKTCTRL0 – Packet automation control**

Bit	Field Name	Reset	R/W	Description										
7	Reserved		R0											
6	WHITE_DATA	1	R/W	Turn data whitening on / off 0: Whitening off 1: Whitening on										
5:4	PKT_FORMAT[1:0]	0 (00)	R/W	Format of RX and TX data <table border="1" style="width: 100%; border-collapse: collapse;"> <thead> <tr> <th>Setting</th> <th>Packet format</th> </tr> </thead> <tbody> <tr> <td>0 (00)</td> <td>Normal mode, use FIFOs for RX and TX</td> </tr> <tr> <td>1 (01)</td> <td>Serial Synchronous mode, used for backwards compatibility</td> </tr> <tr> <td>2 (10)</td> <td>Random TX mode; sends random data using PN9 generator. Used for test. Works as normal mode, setting 0 (00), in RX.</td> </tr> <tr> <td>3 (11)</td> <td>Asynchronous transparent mode. Data in on GDO0 and Data out on either of the GDO pins</td> </tr> </tbody> </table>	Setting	Packet format	0 (00)	Normal mode, use FIFOs for RX and TX	1 (01)	Serial Synchronous mode, used for backwards compatibility	2 (10)	Random TX mode; sends random data using PN9 generator. Used for test. Works as normal mode, setting 0 (00), in RX.	3 (11)	Asynchronous transparent mode. Data in on GDO0 and Data out on either of the GDO pins
Setting	Packet format													
0 (00)	Normal mode, use FIFOs for RX and TX													
1 (01)	Serial Synchronous mode, used for backwards compatibility													
2 (10)	Random TX mode; sends random data using PN9 generator. Used for test. Works as normal mode, setting 0 (00), in RX.													
3 (11)	Asynchronous transparent mode. Data in on GDO0 and Data out on either of the GDO pins													
3	CC2400_EN	0	R/W	Enable CC2400 support. Use same CRC implementation as CC2400.										
2	CRC_EN	1	R/W	1: CRC calculation in TX and CRC check in RX enabled 0: CRC disabled for TX and RX										
1:0	LENGTH_CONFIG[1:0]	1 (01)	R/W	Configure the packet length <table border="1" style="width: 100%; border-collapse: collapse;"> <thead> <tr> <th>Setting</th> <th>Packet length configuration</th> </tr> </thead> <tbody> <tr> <td>0 (00)</td> <td>Fixed length packets, length configured in PKTLEN register</td> </tr> <tr> <td>1 (01)</td> <td>Variable length packets, packet length configured by the first byte after sync word</td> </tr> <tr> <td>2 (10)</td> <td>Enable infinite length packets</td> </tr> <tr> <td>3 (11)</td> <td>Reserved</td> </tr> </tbody> </table>	Setting	Packet length configuration	0 (00)	Fixed length packets, length configured in PKTLEN register	1 (01)	Variable length packets, packet length configured by the first byte after sync word	2 (10)	Enable infinite length packets	3 (11)	Reserved
Setting	Packet length configuration													
0 (00)	Fixed length packets, length configured in PKTLEN register													
1 (01)	Variable length packets, packet length configured by the first byte after sync word													
2 (10)	Enable infinite length packets													
3 (11)	Reserved													

**0x09: ADDR – Device address**

Bit	Field Name	Reset	R/W	Description
7:0	DEVICE_ADDR[7:0]	0 (0x00)	R/W	Address used for packet filtration. Optional broadcast addresses are 0 (0x00) and 255 (0xFF).

**0x0A: CHANNR – Channel number**

Bit	Field Name	Reset	R/W	Description
7:0	CHAN[7:0]	0 (0x00)	R/W	The 8-bit unsigned channel number, which is multiplied by the channel spacing setting and added to the base frequency.



**0x0B: FSCTRL1 – Frequency synthesizer control**

Bit	Field Name	Reset	R/W	Description
7:5	Reserved		R0	
4:0	FREQ_IF[4:0]	10 (0x0F)	R/W	<p>The desired IF frequency to employ in RX. Subtracted from FS base frequency in RX and controls the digital complex mixer in the demodulator.</p> $f_{IF} = \frac{f_{XOSC}}{2^{10}} \cdot FREQ\_IF$ <p>The default value gives an IF frequency of 254kHz, assuming a 26.0MHz crystal.</p>

**0x0C: FSCTRL0 – Frequency synthesizer control**

Bit	Field Name	Reset	R/W	Description
7:0	FREQOFF[7:0]	0 (0x00)	R/W	<p>Frequency offset added to the base frequency before being used by the FS. (2-complement).</p> <p>Resolution is <math>F_{XTAL}/2^{14}</math> (1.5kHz-1.7kHz); range is <math>\pm 186</math>kHz to <math>\pm 217</math>kHz, dependent of XTAL frequency.</p> <p>The SAFC strobe command and the automatic AFC mechanism add the current FREQEST value to FREQOFF.</p>

**0x0D: FREQ2 – Frequency control word, high byte**

Bit	Field Name	Reset	R/W	Description																																				
7:6	FREQ[23:22]	0 (00)	R	FREQ[23:22] is always 0 (the FREQ2 register is less than 36 with 26MHz or higher crystal)																																				
5:0	FREQ[21:16]	30 (0x1E)	R/W	<p>FREQ[23:0] is the base frequency for the frequency synthesiser in increments of <math>F_{XOSC}/2^{16}</math>.</p> $f_{carrier} = \frac{f_{XOSC}}{2^{16}} \cdot FREQ[23:0]$ <p>The default frequency word gives a base frequency of 800MHz, assuming a 26.0MHz crystal. With the default channel spacing settings, the following FREQ2 values and channel numbers can be used:</p> <table border="1"> <thead> <tr> <th>FREQ2</th> <th>Base frequency</th> <th>Frequency range (CHAN numbers)</th> </tr> </thead> <tbody> <tr><td>10 (0x0A)</td><td>280MHz</td><td>300.2MHz-331MHz (101-255)</td></tr> <tr><td>11 (0x0B)</td><td>306MHz</td><td>306MHz-347.8MHz (0-209)</td></tr> <tr><td>14 (0x0E)</td><td>384MHz</td><td>400.2MHz-435MHz (81-255)</td></tr> <tr><td>15 (0x0F)</td><td>410MHz</td><td>410MHz-461MHz (0-255)</td></tr> <tr><td>16 (0x10)</td><td>436MHz</td><td>436MHz-463.8MHz (0-139)</td></tr> <tr><td>17 (0x11)</td><td>462MHz</td><td>462MHz-463.8MHz (0-9)</td></tr> <tr><td>30 (0x1E)</td><td>800MHz</td><td>800.2MHz-851MHz (1-255)</td></tr> <tr><td>31 (0x1F)</td><td>826MHz</td><td>826MHz-877MHz (0-255)</td></tr> <tr><td>32 (0x20)</td><td>852MHz</td><td>852MHz-903MHz (0-255)</td></tr> <tr><td>33 (0x21)</td><td>878MHz</td><td>878MHz-927.8MHz (0-249)</td></tr> <tr><td>34 (0x22)</td><td>904MHz</td><td>904MHz-927.8MHz (0-119)</td></tr> </tbody> </table>	FREQ2	Base frequency	Frequency range (CHAN numbers)	10 (0x0A)	280MHz	300.2MHz-331MHz (101-255)	11 (0x0B)	306MHz	306MHz-347.8MHz (0-209)	14 (0x0E)	384MHz	400.2MHz-435MHz (81-255)	15 (0x0F)	410MHz	410MHz-461MHz (0-255)	16 (0x10)	436MHz	436MHz-463.8MHz (0-139)	17 (0x11)	462MHz	462MHz-463.8MHz (0-9)	30 (0x1E)	800MHz	800.2MHz-851MHz (1-255)	31 (0x1F)	826MHz	826MHz-877MHz (0-255)	32 (0x20)	852MHz	852MHz-903MHz (0-255)	33 (0x21)	878MHz	878MHz-927.8MHz (0-249)	34 (0x22)	904MHz	904MHz-927.8MHz (0-119)
FREQ2	Base frequency	Frequency range (CHAN numbers)																																						
10 (0x0A)	280MHz	300.2MHz-331MHz (101-255)																																						
11 (0x0B)	306MHz	306MHz-347.8MHz (0-209)																																						
14 (0x0E)	384MHz	400.2MHz-435MHz (81-255)																																						
15 (0x0F)	410MHz	410MHz-461MHz (0-255)																																						
16 (0x10)	436MHz	436MHz-463.8MHz (0-139)																																						
17 (0x11)	462MHz	462MHz-463.8MHz (0-9)																																						
30 (0x1E)	800MHz	800.2MHz-851MHz (1-255)																																						
31 (0x1F)	826MHz	826MHz-877MHz (0-255)																																						
32 (0x20)	852MHz	852MHz-903MHz (0-255)																																						
33 (0x21)	878MHz	878MHz-927.8MHz (0-249)																																						
34 (0x22)	904MHz	904MHz-927.8MHz (0-119)																																						

**0x0E: FREQ1 – Frequency control word, middle byte**

Bit	Field Name	Reset	R/W	Description
7:0	FREQ[15:8]	196 (0xC4)	R/W	Ref. FREQ2 register

**0x0F: FREQ0 – Frequency control word, low byte**

Bit	Field Name	Reset	R/W	Description
7:0	FREQ[7:0]	236 (0xEC)	R/W	Ref. FREQ2 register

**0x10: MDMCFG4 – Modem configuration**

Bit	Field Name	Reset	R/W	Description
7:6	CHANBW_E[1:0]	2 (10)	R/W	
5:4	CHANBW_M[1:0]	0 (00)	R/W	<p>Sets the decimation ratio for the delta-sigma ADC input stream and thus the channel bandwidth.</p> $BW_{channel} = \frac{f_{XOSC}}{8 \cdot (4 + CHANBW\_M) \cdot 2^{CHANBW\_E}}$ <p>Note that the combination CHANBW_E=0 and CHANBW_M=0 is not supported.</p> <p>The default values give 203kHz channel filter bandwidth, assuming a 26.0MHz crystal.</p>
3:0	DRATE_E[3:0]	12 (1100)	R/W	The exponent of the user specified symbol rate

**0x11: MDMCFG3 – Modem configuration**

Bit	Field Name	Reset	R/W	Description
7:0	DRATE_M[7:0]	34 (0x22)	R/W	<p>The mantissa of the user specified symbol rate. The symbol rate is configured using an unsigned, floating-point number with 9-bit mantissa and 4-bit exponent. The 9<sup>th</sup> bit is a hidden '1'. The resulting data rate is:</p> $R_{DATA} = \frac{(256 + DRATE\_M) \cdot 2^{DRATE\_E}}{2^{28}} \cdot f_{XOSC}$ <p>The default values give a data rate of 115.051kbps (closest setting to 115.2kbps), assuming a 26.0MHz crystal.</p>

**0x12: MDMCFG2 – Modem configuration**

Bit	Field Name	Reset	R/W	Description																		
7	DEM_DCFILT_OFF	0	R/W	Disable digital DC blocking filter before demodulator.																		
6:4	MOD_FORMAT[2:0]	0 (000)	R/W	<p>The modulation format of the radio signal</p> <table border="1"> <thead> <tr> <th>Setting</th> <th>Modulation format</th> </tr> </thead> <tbody> <tr> <td>0 (000)</td> <td>2-FSK</td> </tr> <tr> <td>1 (001)</td> <td>GFSK</td> </tr> <tr> <td>2 (010)</td> <td>-</td> </tr> <tr> <td>3 (011)</td> <td>ASK/OOK</td> </tr> <tr> <td>4 (100)</td> <td>-</td> </tr> <tr> <td>5 (101)</td> <td>-</td> </tr> <tr> <td>6 (110)</td> <td>-</td> </tr> <tr> <td>7 (111)</td> <td>MSK</td> </tr> </tbody> </table>	Setting	Modulation format	0 (000)	2-FSK	1 (001)	GFSK	2 (010)	-	3 (011)	ASK/OOK	4 (100)	-	5 (101)	-	6 (110)	-	7 (111)	MSK
Setting	Modulation format																					
0 (000)	2-FSK																					
1 (001)	GFSK																					
2 (010)	-																					
3 (011)	ASK/OOK																					
4 (100)	-																					
5 (101)	-																					
6 (110)	-																					
7 (111)	MSK																					
3	MANCHESTER_EN	0	R/W	Enables Manchester encoding/decoding.																		
2:0	SYNC_MODE[2:0]	2 (010)	R/W	<p>Combined sync-word qualifier mode.</p> <p>The values 0 (000) and 4 (100) disables sync word transmission in TX and sync word detection in RX.</p> <p>The values 1 (001), 2 (001), 5 (101) and 6 (110) enables 16-bit sync word transmission in TX and 16-bits sync word detection in RX. Only 15 of 16 bits need to match in RX when using setting 1 (001) or 5 (101). The values 3 (011) and 7 (111) enables repeated sync word transmission in RX and 32-bits sync word detection in RX (only 30 of 32 bits need to match).</p> <table border="1"> <thead> <tr> <th>Setting</th> <th>Sync-word qualifier mode</th> </tr> </thead> <tbody> <tr> <td>0 (000)</td> <td>No preamble/sync</td> </tr> <tr> <td>1 (001)</td> <td>15/16 sync word bits detected</td> </tr> <tr> <td>2 (010)</td> <td>16/16 sync word bits detected</td> </tr> <tr> <td>3 (011)</td> <td>30/32 sync word bits detected</td> </tr> <tr> <td>4 (100)</td> <td>No preamble/sync, carrier-sense above threshold</td> </tr> <tr> <td>5 (101)</td> <td>15/16 + carrier-sense above threshold</td> </tr> <tr> <td>6 (110)</td> <td>16/16 + carrier-sense above threshold</td> </tr> <tr> <td>7 (111)</td> <td>30/32 + carrier-sense above threshold</td> </tr> </tbody> </table>	Setting	Sync-word qualifier mode	0 (000)	No preamble/sync	1 (001)	15/16 sync word bits detected	2 (010)	16/16 sync word bits detected	3 (011)	30/32 sync word bits detected	4 (100)	No preamble/sync, carrier-sense above threshold	5 (101)	15/16 + carrier-sense above threshold	6 (110)	16/16 + carrier-sense above threshold	7 (111)	30/32 + carrier-sense above threshold
Setting	Sync-word qualifier mode																					
0 (000)	No preamble/sync																					
1 (001)	15/16 sync word bits detected																					
2 (010)	16/16 sync word bits detected																					
3 (011)	30/32 sync word bits detected																					
4 (100)	No preamble/sync, carrier-sense above threshold																					
5 (101)	15/16 + carrier-sense above threshold																					
6 (110)	16/16 + carrier-sense above threshold																					
7 (111)	30/32 + carrier-sense above threshold																					

**0x13: MDMCFG1– Modem configuration**

Bit	Field Name	Reset	R/W	Description																		
7	FEC_EN	0	R/W	Enable Forward Error Correction (FEC) with interleaving for packet payload																		
6:4	NUM_PREAMBLE[2:0]	2 (010)	R/W	<p>Sets the minimum number of preamble bytes to be transmitted</p> <table border="1"> <thead> <tr> <th>Setting</th> <th>Number of preamble bytes</th> </tr> </thead> <tbody> <tr> <td>0 (000)</td> <td>2</td> </tr> <tr> <td>1 (001)</td> <td>3</td> </tr> <tr> <td>2 (010)</td> <td>4</td> </tr> <tr> <td>3 (011)</td> <td>6</td> </tr> <tr> <td>4 (100)</td> <td>8</td> </tr> <tr> <td>5 (101)</td> <td>12</td> </tr> <tr> <td>6 (110)</td> <td>16</td> </tr> <tr> <td>7 (111)</td> <td>24</td> </tr> </tbody> </table>	Setting	Number of preamble bytes	0 (000)	2	1 (001)	3	2 (010)	4	3 (011)	6	4 (100)	8	5 (101)	12	6 (110)	16	7 (111)	24
Setting	Number of preamble bytes																					
0 (000)	2																					
1 (001)	3																					
2 (010)	4																					
3 (011)	6																					
4 (100)	8																					
5 (101)	12																					
6 (110)	16																					
7 (111)	24																					
3:2	Reserved		R0																			
1:0	CHANSPC_E[1:0]	2 (10)	R/W	2 bit exponent of channel spacing																		

**0x14: MDMCFG0– Modem configuration**

Bit	Field Name	Reset	R/W	Description
7:0	CHANSPC_M[7:0]	248 (0xF8)	R/W	<p>8-bit mantissa of channel spacing (initial 1 assumed). The channel spacing is multiplied by the channel number CHAN and added to the base frequency. It is unsigned and has the format:</p> $\Delta f_{CHANNEL} = \frac{f_{XOSC}}{2^{18}} \cdot (256 + CHANSPC\_M) \cdot 2^{CHANSPC\_E} \cdot CHAN$ <p>The default values give 199.951kHz channel spacing (the closest setting to 200kHz), assuming 26.0MHz crystal frequency.</p>

**0x15: DEVIATN – Modem deviation setting**

Bit	Field Name	Reset	R/W	Description
7	Reserved		R0	
6:4	DEVIATION_E[2:0]	4 (100)	R/W	Deviation exponent
3	Reserved		R0	
2:0	DEVIATION_M[2:0]	7 (111)	R/W	<p>When MSK modulation is enabled: Sets fraction of symbol period used for phase change.</p> <p>When 2-FSK/GFSK modulation is enabled: Deviation mantissa, interpreted as a 4-bit value with MSB implicit 1. The resulting frequency deviation is given by:</p> $f_{dev} = \frac{f_{xosc}}{2^{17}} \cdot (8 + DEVIATION\_M) \cdot 2^{DEVIATION\_E}$ <p>The default values give ±47.607kHz deviation, assuming 26.0MHz crystal frequency.</p>

**0x16: MCSM2 – Main Radio Control State Machine configuration**

Bit	Field Name	Reset	R/W	Description																											
7:5	Reserved		R0	Reserved																											
4	RX_TIME_RSSI	0	R/W	Direct RX termination based on RSSI measurement (carrier sense). For ASK/OOK modulation, RX times out if there is no carrier sense in the first 8 symbol periods.																											
3	RX_TIME_QUAL	0	R/W	When the RX_TIME timer expires, the chip checks if sync word is found when RX_TIME_QUAL=0, or either sync word is found or PQI is set when RX_TIME_QUAL=1.																											
2:0	RX_TIME[2:0]	7 (111)	R/W	<p>Timeout for sync word search in RX. The timeout is relative to the programmed EVENT0 timeout, which means that the duty cycle can be set in wake-on-radio (WOR) mode. The RX timeout is scaled by 1 bit less than the EVENT0 timeout with respect to the WORCTRL.WOR_RES setting, as very long timeouts probably also will use very low RX duty cycles.</p> <table border="1"> <thead> <tr> <th>Setting</th> <th>RX timeout</th> <th>Duty cycle, WOR</th> </tr> </thead> <tbody> <tr> <td>0 (000)</td> <td><math>T_{EVENT0} / 2^{(3+WOR\_RES)}</math></td> <td>12.5% / <math>2^{WOR\_RES}</math></td> </tr> <tr> <td>1 (001)</td> <td><math>T_{EVENT0} / 2^{(4+WOR\_RES)}</math></td> <td>6.25% / <math>2^{WOR\_RES}</math></td> </tr> <tr> <td>2 (010)</td> <td><math>T_{EVENT0} / 2^{(5+WOR\_RES)}</math></td> <td>3.125% / <math>2^{WOR\_RES}</math></td> </tr> <tr> <td>3 (011)</td> <td><math>T_{EVENT0} / 2^{(6+WOR\_RES)}</math></td> <td>1.563% / <math>2^{WOR\_RES}</math></td> </tr> <tr> <td>4 (100)</td> <td><math>T_{EVENT0} / 2^{(7+WOR\_RES)}</math></td> <td>0.781% / <math>2^{WOR\_RES}</math></td> </tr> <tr> <td>5 (101)</td> <td><math>T_{EVENT0} / 2^{(8+WOR\_RES)}</math></td> <td>0.391% / <math>2^{WOR\_RES}</math></td> </tr> <tr> <td>6 (110)</td> <td><math>T_{EVENT0} / 2^{(9+WOR\_RES)}</math></td> <td>0.195% / <math>2^{WOR\_RES}</math></td> </tr> <tr> <td>7 (111)</td> <td>Until end of packet</td> <td>N/A (no timeout)</td> </tr> </tbody> </table> <p>Note that the RC oscillator must be enabled in order to use setting 0-6, because the timeout counts RC oscillator periods. WOR mode does not need to be enabled. The timeout counter resolution is limited: With RX_TIME=0, the timeout count is given by the 13MSBs of EVENT0, decreasing to the 7MSBs of EVENT0 with RX_TIME=6.</p>	Setting	RX timeout	Duty cycle, WOR	0 (000)	$T_{EVENT0} / 2^{(3+WOR\_RES)}$	12.5% / $2^{WOR\_RES}$	1 (001)	$T_{EVENT0} / 2^{(4+WOR\_RES)}$	6.25% / $2^{WOR\_RES}$	2 (010)	$T_{EVENT0} / 2^{(5+WOR\_RES)}$	3.125% / $2^{WOR\_RES}$	3 (011)	$T_{EVENT0} / 2^{(6+WOR\_RES)}$	1.563% / $2^{WOR\_RES}$	4 (100)	$T_{EVENT0} / 2^{(7+WOR\_RES)}$	0.781% / $2^{WOR\_RES}$	5 (101)	$T_{EVENT0} / 2^{(8+WOR\_RES)}$	0.391% / $2^{WOR\_RES}$	6 (110)	$T_{EVENT0} / 2^{(9+WOR\_RES)}$	0.195% / $2^{WOR\_RES}$	7 (111)	Until end of packet	N/A (no timeout)
Setting	RX timeout	Duty cycle, WOR																													
0 (000)	$T_{EVENT0} / 2^{(3+WOR\_RES)}$	12.5% / $2^{WOR\_RES}$																													
1 (001)	$T_{EVENT0} / 2^{(4+WOR\_RES)}$	6.25% / $2^{WOR\_RES}$																													
2 (010)	$T_{EVENT0} / 2^{(5+WOR\_RES)}$	3.125% / $2^{WOR\_RES}$																													
3 (011)	$T_{EVENT0} / 2^{(6+WOR\_RES)}$	1.563% / $2^{WOR\_RES}$																													
4 (100)	$T_{EVENT0} / 2^{(7+WOR\_RES)}$	0.781% / $2^{WOR\_RES}$																													
5 (101)	$T_{EVENT0} / 2^{(8+WOR\_RES)}$	0.391% / $2^{WOR\_RES}$																													
6 (110)	$T_{EVENT0} / 2^{(9+WOR\_RES)}$	0.195% / $2^{WOR\_RES}$																													
7 (111)	Until end of packet	N/A (no timeout)																													

**0x17: MCSM1– Main Radio Control State Machine configuration**

Bit	Field Name	Reset	R/W	Description										
7:6	Reserved		R0											
5:4	CCA_MODE[1:0]	3 (11)	R/W	<p>Selects CCA_MODE; Reflected in CCA signal</p> <table border="1"> <thead> <tr> <th>Setting</th> <th>Clear channel indication</th> </tr> </thead> <tbody> <tr> <td>0 (00)</td> <td>Always</td> </tr> <tr> <td>1 (01)</td> <td>If RSSI below threshold</td> </tr> <tr> <td>2 (10)</td> <td>Unless currently receiving a packet</td> </tr> <tr> <td>3 (11)</td> <td>If RSSI below threshold unless currently receiving a packet</td> </tr> </tbody> </table>	Setting	Clear channel indication	0 (00)	Always	1 (01)	If RSSI below threshold	2 (10)	Unless currently receiving a packet	3 (11)	If RSSI below threshold unless currently receiving a packet
Setting	Clear channel indication													
0 (00)	Always													
1 (01)	If RSSI below threshold													
2 (10)	Unless currently receiving a packet													
3 (11)	If RSSI below threshold unless currently receiving a packet													
3:2	RXOFF_MODE[1:0]	0 (00)	R/W	<p>Select what should happen when a packet has been received</p> <table border="1"> <thead> <tr> <th>Setting</th> <th>Next state after finishing packet reception</th> </tr> </thead> <tbody> <tr> <td>0 (00)</td> <td>IDLE</td> </tr> <tr> <td>1 (01)</td> <td>FSTXON</td> </tr> <tr> <td>2 (10)</td> <td>TX</td> </tr> <tr> <td>3 (11)</td> <td>Stay in RX</td> </tr> </tbody> </table>	Setting	Next state after finishing packet reception	0 (00)	IDLE	1 (01)	FSTXON	2 (10)	TX	3 (11)	Stay in RX
Setting	Next state after finishing packet reception													
0 (00)	IDLE													
1 (01)	FSTXON													
2 (10)	TX													
3 (11)	Stay in RX													
1:0	TXOFF_MODE[1:0]	0 (00)	R/W	<p>Select what should happen when a packet has been sent (TX)</p> <table border="1"> <thead> <tr> <th>Setting</th> <th>Next state after finishing packet transmission</th> </tr> </thead> <tbody> <tr> <td>0 (00)</td> <td>IDLE</td> </tr> <tr> <td>1 (01)</td> <td>FSTXON</td> </tr> <tr> <td>2 (10)</td> <td>Stay in TX (start sending preamble)</td> </tr> <tr> <td>3 (11)</td> <td>RX</td> </tr> </tbody> </table>	Setting	Next state after finishing packet transmission	0 (00)	IDLE	1 (01)	FSTXON	2 (10)	Stay in TX (start sending preamble)	3 (11)	RX
Setting	Next state after finishing packet transmission													
0 (00)	IDLE													
1 (01)	FSTXON													
2 (10)	Stay in TX (start sending preamble)													
3 (11)	RX													

**0x18: MCSM0– Main Radio Control State Machine configuration**

Bit	Field Name	Reset	R/W	Description															
7:6	Reserved		R0																
5:4	FS_AUTOCAL[1:0]	0 (00)	R/W	<p>Automatically calibrate when going to RX or TX, or back to IDLE</p> <table border="1"> <thead> <tr> <th>Setting</th> <th>When to perform automatic calibration</th> </tr> </thead> <tbody> <tr> <td>0 (00)</td> <td>Never (manually calibrate using SCAL strobe)</td> </tr> <tr> <td>1 (01)</td> <td>When going from IDLE to RX or TX (or FSTXON)</td> </tr> <tr> <td>2 (10)</td> <td>When going from RX or TX back to IDLE</td> </tr> <tr> <td>3 (11)</td> <td>Every 4<sup>th</sup> time when going from RX or TX to IDLE</td> </tr> </tbody> </table> <p>In some automatic wake-on-radio (WOR) applications, using setting 3 (11) can significantly reduce current consumption.</p>	Setting	When to perform automatic calibration	0 (00)	Never (manually calibrate using SCAL strobe)	1 (01)	When going from IDLE to RX or TX (or FSTXON)	2 (10)	When going from RX or TX back to IDLE	3 (11)	Every 4 <sup>th</sup> time when going from RX or TX to IDLE					
Setting	When to perform automatic calibration																		
0 (00)	Never (manually calibrate using SCAL strobe)																		
1 (01)	When going from IDLE to RX or TX (or FSTXON)																		
2 (10)	When going from RX or TX back to IDLE																		
3 (11)	Every 4 <sup>th</sup> time when going from RX or TX to IDLE																		
3:2	PO_TIMEOUT	1 (01)	R/W	<p>Programs the number of times the six-bit ripple counter must expire before CHP_RDY_N goes low. Values other than 0 (00) are most useful when the XOSC is left on during power-down.</p> <table border="1"> <thead> <tr> <th>Setting</th> <th>Expire count</th> <th>Timeout after XOSC start</th> </tr> </thead> <tbody> <tr> <td>0 (00)</td> <td>1</td> <td>Approx. 2.3µs – 2.7µs</td> </tr> <tr> <td>1 (01)</td> <td>16</td> <td>Approx. 37µs – 43µs</td> </tr> <tr> <td>2 (10)</td> <td>64</td> <td>Approx. 146µs – 171µs</td> </tr> <tr> <td>3 (11)</td> <td>256</td> <td>Approx. 585µs – 683µs</td> </tr> </tbody> </table> <p>Exact timeout depends on crystal frequency.</p>	Setting	Expire count	Timeout after XOSC start	0 (00)	1	Approx. 2.3µs – 2.7µs	1 (01)	16	Approx. 37µs – 43µs	2 (10)	64	Approx. 146µs – 171µs	3 (11)	256	Approx. 585µs – 683µs
Setting	Expire count	Timeout after XOSC start																	
0 (00)	1	Approx. 2.3µs – 2.7µs																	
1 (01)	16	Approx. 37µs – 43µs																	
2 (10)	64	Approx. 146µs – 171µs																	
3 (11)	256	Approx. 585µs – 683µs																	
1	PIN_CTRL_EN	0	R/W	Enables the pin radio control option															
0	XOSC_FORCE_ON	0	R/W	Force the XOSC to stay on in the SLEEP state.															

**0x19: FOCCFG – Frequency Offset Compensation configuration**

Bit	Field Name	Reset	R/W	Description
7:6	Reserved		R0	
5:0	FOCCFG[5:0]	54 (0x36)	R/W	Frequency offset compensation configuration. The value to use in this register is given by the SmartRF® Studio software.

**0x1A: BSCFG – Bit Synchronization configuration**

Bit	Field Name	Reset	R/W	Description
7:0	BSCFG[7:0]	108 (0x6C)	R/W	Bit Synchronization configuration. The value to use in this register is given by the SmartRF® Studio software.

**0x1B: AGCCTRL2 – AGC control**

Bit	Field Name	Reset	R/W	Description
7:0	AGCCTRL2[7:0]	3 (0x03)	R/W	AGC control register. The value to use in this register is given by the SmartRF® Studio software.

**0x1C: AGCCTRL1 – AGC control**

Bit	Field Name	Reset	R/W	Description
7	Reserved		R0	
6:0	AGCCTRL1[6:0]	64 (0x40)	R/W	AGC control register. The value to use in this register is given by the SmartRF® Studio software.

**0x1D: AGCCTRL0 – AGC control**

Bit	Field Name	Reset	R/W	Description
7:0	AGCCTRL0[7:0]	145 (0x91)	R/W	AGC control register. The value to use in this register is given by the SmartRF® Studio software.

**0x1E: WOREVT1 – High byte event0 timeout**

Bit	Field Name	Reset	R/W	Description
7:0	EVENT0[15:8]	135 (0x87)	R/W	High byte of Event 0 timeout register  $t_{Event0} = \frac{750}{f_{XOSC}} \cdot EVENT0 \cdot 2^{5-WOR\_RES}$

**0x1F: WOREVT0 –Low byte event0 timeout**

Bit	Field Name	Reset	R/W	Description
7:0	EVENT0[7:0]	107 (0x6B)	R/W	Low byte of Event 0 timeout register.  The default Event 0 value gives 1.0s timeout, assuming a 26.0MHz crystal.



0x20: WORCTRL – Wake On Radio control

Bit	Field Name	Reset	R/W	Description																											
7	RC_PD	1	R/W	Power down signal to RC oscillator. When written to 0, automatic initial calibration will be performed																											
6:4	EVENT1[2:0]	7 (111)	R/W	<p>Timeout setting from register block. Decoded to Event 1 timeout. RC oscillator clock frequency equals <math>F_{XOSC}/750</math>, which is 32kHz-37kHz, depending on crystal frequency. The table below lists the number of clock periods after Event 0 before Event 1 times out.</p> <table border="1"> <thead> <tr> <th>Setting</th> <th>WOR_AUTOSYNC=0</th> <th>WOR_AUTOSYNC=1</th> </tr> </thead> <tbody> <tr> <td>0 (000)</td> <td>4 (0.107ms – 0.125ms)</td> <td>16 (0.429ms – 0.5ms)</td> </tr> <tr> <td>1 (001)</td> <td>6 (0.161ms – 0.188ms)</td> <td>24 (0.643ms – 0.75ms)</td> </tr> <tr> <td>2 (010)</td> <td>8 (0.214ms – 0.25ms)</td> <td>32 (0.857ms – 1ms)</td> </tr> <tr> <td>3 (011)</td> <td>12 (0.321ms – 0.375ms)</td> <td>48 (1.286ms – 1.5ms)</td> </tr> <tr> <td>4 (100)</td> <td>16 (0.429ms – 0.5ms)</td> <td>64 (1.7ms – 2ms)</td> </tr> <tr> <td>5 (101)</td> <td>24 (0.643ms – 0.75ms)</td> <td>96 (2.6ms – 3ms)</td> </tr> <tr> <td>6 (110)</td> <td>32 (0.857ms – 1ms)</td> <td>128 (3.4ms – 4ms)</td> </tr> <tr> <td>7 (111)</td> <td>48 (1.286ms – 1.5ms)</td> <td>192 (5.1ms – 6ms)</td> </tr> </tbody> </table>	Setting	WOR_AUTOSYNC=0	WOR_AUTOSYNC=1	0 (000)	4 (0.107ms – 0.125ms)	16 (0.429ms – 0.5ms)	1 (001)	6 (0.161ms – 0.188ms)	24 (0.643ms – 0.75ms)	2 (010)	8 (0.214ms – 0.25ms)	32 (0.857ms – 1ms)	3 (011)	12 (0.321ms – 0.375ms)	48 (1.286ms – 1.5ms)	4 (100)	16 (0.429ms – 0.5ms)	64 (1.7ms – 2ms)	5 (101)	24 (0.643ms – 0.75ms)	96 (2.6ms – 3ms)	6 (110)	32 (0.857ms – 1ms)	128 (3.4ms – 4ms)	7 (111)	48 (1.286ms – 1.5ms)	192 (5.1ms – 6ms)
Setting	WOR_AUTOSYNC=0	WOR_AUTOSYNC=1																													
0 (000)	4 (0.107ms – 0.125ms)	16 (0.429ms – 0.5ms)																													
1 (001)	6 (0.161ms – 0.188ms)	24 (0.643ms – 0.75ms)																													
2 (010)	8 (0.214ms – 0.25ms)	32 (0.857ms – 1ms)																													
3 (011)	12 (0.321ms – 0.375ms)	48 (1.286ms – 1.5ms)																													
4 (100)	16 (0.429ms – 0.5ms)	64 (1.7ms – 2ms)																													
5 (101)	24 (0.643ms – 0.75ms)	96 (2.6ms – 3ms)																													
6 (110)	32 (0.857ms – 1ms)	128 (3.4ms – 4ms)																													
7 (111)	48 (1.286ms – 1.5ms)	192 (5.1ms – 6ms)																													
3	RC_CAL	1	R/W	Enables (1) or disables (0) the RC oscillator calibration. Included for test purposes only.																											
2	Reserved		R0																												
1:0	WOR_RES	0 (00)	R/W	<p>Controls the Event 0 resolution and maximum timeout of the WOR module:</p> <table border="1"> <thead> <tr> <th>Setting</th> <th>Resolution (1 LSB)</th> <th>Max timeout</th> </tr> </thead> <tbody> <tr> <td>0 (00)</td> <td>1 period (27<math>\mu</math>s – 31<math>\mu</math>s)</td> <td>1.8 – 2.0 seconds</td> </tr> <tr> <td>1 (01)</td> <td>2<sup>5</sup> periods (0.86ms – 1.0ms)</td> <td>56 – 66 seconds</td> </tr> <tr> <td>2 (10)</td> <td>2<sup>10</sup> periods (27ms – 32ms)</td> <td>30 – 35 minutes</td> </tr> <tr> <td>3 (11)</td> <td>2<sup>15</sup> periods (0.88s – 1.0s)</td> <td>16 – 18 hours</td> </tr> </tbody> </table> <p>Adjusting the resolution does not affect the resolution of the WOR time readout registers <code>WORTIME1/WORTIME0</code>.</p>	Setting	Resolution (1 LSB)	Max timeout	0 (00)	1 period (27 $\mu$ s – 31 $\mu$ s)	1.8 – 2.0 seconds	1 (01)	2 <sup>5</sup> periods (0.86ms – 1.0ms)	56 – 66 seconds	2 (10)	2 <sup>10</sup> periods (27ms – 32ms)	30 – 35 minutes	3 (11)	2 <sup>15</sup> periods (0.88s – 1.0s)	16 – 18 hours												
Setting	Resolution (1 LSB)	Max timeout																													
0 (00)	1 period (27 $\mu$ s – 31 $\mu$ s)	1.8 – 2.0 seconds																													
1 (01)	2 <sup>5</sup> periods (0.86ms – 1.0ms)	56 – 66 seconds																													
2 (10)	2 <sup>10</sup> periods (27ms – 32ms)	30 – 35 minutes																													
3 (11)	2 <sup>15</sup> periods (0.88s – 1.0s)	16 – 18 hours																													

0x21: FRENDD1 – Front end RX configuration

Bit	Field Name	Reset	R/W	Description
7:0	FRENDD1[7:0]	166 (0xA6)	R/W	Front end RX configuration. The value to use in this register is given by the SmartRF <sup>®</sup> Studio software.

**0x22: FRENDO – Front end TX configuration**

Bit	Field Name	Reset	R/W	Description
7:6	Reserved		R0	
5:4	LODIV_BUF_CURRENT_TX[1:0]	1 (01)	R/W	Adjusts current TX LO buffer (input to PA). The value to use in this field is given by the SmartRF® Studio software.
3	Reserved		R0	
2:0	PA_POWER[2:0]	0 (000)	R/W	Selects PA power setting. This value is an index to the PATABLE, which can be programmed with up to 8 different PA settings. In ASK mode, this selects the PATABLE index to use when transmitting a '1'. PATABLE index zero is used in ASK when transmitting a '0'. The PATABLE settings from index '0' to the PA_POWER value are used for ASK TX shaping, and for power ramp-up/ramp-down at the start/end of transmission in all TX modulation formats.

**0x23: FSCAL3 – Frequency synthesizer calibration**

Bit	Field Name	Reset	R/W	Description
7:0	FSCAL3[7:0]	169 (0xA9)	R/W	Frequency synthesizer calibration configuration and result register. The value to write in this register before calibration is given by the SmartRF® Studio software. Fast frequency hopping without calibration for each hop can be done by calibrating upfront for each frequency and saving the resulting FSCAL3, FSCAL2 and FSCAL1 register values. Between each frequency hop, calibration can be replaced by writing the FSCAL3, FSCAL2 and FSCAL1 register values corresponding to the next RF frequency.

**0x24: FSCAL2 – Frequency synthesizer calibration**

Bit	Field Name	Reset	R/W	Description
7:6	Reserved		R0	
5:0	FSCAL2[5:0]	10 (0x0A)	R/W	Frequency synthesizer calibration result register. Fast frequency hopping without calibration for each hop can be done by calibrating upfront for each frequency and saving the resulting FSCAL3, FSCAL2 and FSCAL1 register values. Between each frequency hop, calibration can be replaced by writing the FSCAL3, FSCAL2 and FSCAL1 register values corresponding to the next RF frequency.

**0x25: FSCAL1 – Frequency synthesizer calibration**

Bit	Field Name	Reset	R/W	Description
7:6	Reserved		R0	
5:0	FSCAL1[5:0]	32 (0x20)	R/W	Frequency synthesizer calibration result register. Fast frequency hopping without calibration for each hop can be done by calibrating upfront for each frequency and saving the resulting FSCAL3, FSCAL2 and FSCAL1 register values. Between each frequency hop, calibration can be replaced by writing the FSCAL3, FSCAL2 and FSCAL1 register values corresponding to the next RF frequency.

**0x26: FSCAL0 – Frequency synthesizer calibration**

Bit	Field Name	Reset	R/W	Description
7	Reserved		R0	
6:0	FSCAL0[6:0]	13 (0x0D)	R/W	Frequency synthesizer calibration control. The value to use in this register is given by the SmartRF® Studio software.

**0x27: RCCTRL1 – RC oscillator configuration**

Bit	Field Name	Reset	R/W	Description
7	Reserved	0	R0	
6:0	RCCTRL1[6:0]	65 (0x41)	R/W	RC oscillator configuration. Do not write to this register.

**0x28: RCCTRL0 – RC oscillator configuration**

Bit	Field Name	Reset	R/W	Description
7	Reserved	0	R0	
6:0	RCCTRL0[6:0]	0 (0x00)	R/W	RC oscillator configuration. Do not write to this register.

**37.2 Configuration Register Details – Registers that loose programming in sleep state**
**0x29: FSTEST – Frequency synthesizer calibration control**

Bit	Field Name	Reset	R/W	Description
7:0	FSTEST[7:0]	87 (0x57)	R/W	For test only. Do not write to this register.

**0x2A: PTEST – Production test**

Bit	Field Name	Reset	R/W	Description
7:0	PTEST[7:0]	127 (0x7F)	R/W	Writing 0xBF to this register makes the on-chip temperature sensor available in the IDLE state. The default 0x7F value should then be written back before leaving the IDLE state. Other use of this register is for test only.

**0x2B: AGCTEST – AGC test**

Bit	Field Name	Reset	R/W	Description
7:0	AGCTEST[7:0]	63 (0x3F)	R/W	For test only. Do not write to this register.

**0x2C: TEST2 – Various test settings**

Bit	Field Name	Reset	R/W	Description
7:0	TEST2[7:0]	136 (0x88)	R/W	For test only. Do not write to this register.

**0x2D: TEST1 – Various test settings**

Bit	Field Name	Reset	R/W	Description
7:0	TEST1[7:0]	49 (0x31)	R/W	For test only. Do not write to this register.

**0x2E: TEST0 – Various test settings**

Bit	Field Name	Reset	R/W	Description
7:0	TEST0[7:0]	11 (0x0B)	R/W	For test only. Do not write to this register.

**37.3 Status register details**

**0x30 (0xF0): PARTNUM – Chip ID**

Bit	Field Name	Reset	R/W	Description
7:0	PARTNUM[7:0]	0 (0x00)	R	Chip part number

**0x31 (0xF1): VERSION – Chip ID**

Bit	Field Name	Reset	R/W	Description
7:0	VERSION[7:0]	2 (0x10)	R	Chip version number.

**0x32 (0xF2): FREQEST – Frequency Offset Estimate from demodulator**

Bit	Field Name	Reset	R/W	Description
7:0	FREQOFF_EST		R	The estimated frequency offset (two's complement) of the carrier. Resolution is $F_{XTAL}/2^{14}$ (1.5kHz-1.7kHz); range is $\pm 186$ kHz to $\pm 217$ kHz, dependent of XTAL frequency.  Frequency offset compensation is only supported for 2-FSK, GFSK and MSK modulation. This register will read 0 when using ASK or OOK modulation.

**0x33 (0xF3): LQI – Demodulator estimate for Link Quality**

Bit	Field Name	Reset	R/W	Description
7	CRC OK		R	The last CRC comparison matched. Cleared when entering/restarting RX mode.
6:0	LQI_EST[6:0]		R	The Link Quality Indicator estimates how easily a received signal can be demodulated. Calculated over the 64 symbols following the sync word (first 8 packet bytes).

**0x34 (0xF4): RSSI – Received signal strength indication**

Bit	Field Name	Reset	R/W	Description
7:0	RSSI		R	Received signal strength indicator

**0x35 (0xF5): MARCSTATE – Main Radio Control State Machine state**

Bit	Field Name	Reset	R/W	Description																																																																											
7:5	Reserved		R0																																																																												
4:0	MARC_STATE[4:0]		R	<table border="1"> <thead> <tr> <th colspan="3">Main Radio Control FSM State</th> </tr> <tr> <th>Value</th> <th>State name</th> <th>State (Figure 10, page 30)</th> </tr> </thead> <tbody> <tr><td>0 (0x00)</td><td>SLEEP</td><td>SLEEP</td></tr> <tr><td>1 (0x01)</td><td>IDLE</td><td>IDLE</td></tr> <tr><td>2 (0x02)</td><td>XOFF</td><td>XOFF</td></tr> <tr><td>3 (0x03)</td><td>VCOON_MC</td><td>MANCAL</td></tr> <tr><td>4 (0x04)</td><td>REGON_MC</td><td>MANCAL</td></tr> <tr><td>5 (0x05)</td><td>MANCAL</td><td>MANCAL</td></tr> <tr><td>6 (0x06)</td><td>VCOON</td><td>FS_WAKEUP</td></tr> <tr><td>7 (0x07)</td><td>REGON</td><td>FS_WAKEUP</td></tr> <tr><td>8 (0x08)</td><td>STARTCAL</td><td>CALIBRATE</td></tr> <tr><td>9 (0x09)</td><td>BWBOOST</td><td>SETTLING</td></tr> <tr><td>10 (0x0A)</td><td>FS_LOCK</td><td>SETTLING</td></tr> <tr><td>11 (0x0B)</td><td>IFADCON</td><td>SETTLING</td></tr> <tr><td>12 (0x0C)</td><td>ENDCAL</td><td>CALIBRATE</td></tr> <tr><td>13 (0x0D)</td><td>RX</td><td>RX</td></tr> <tr><td>14 (0x0E)</td><td>RX_END</td><td>RX</td></tr> <tr><td>15 (0x0F)</td><td>RX_RST</td><td>RX</td></tr> <tr><td>16 (0x10)</td><td>TXRX_SWITCH</td><td>TXRX_SETTLING</td></tr> <tr><td>17 (0x11)</td><td>RX_OVERFLOW</td><td>RX_OVERFLOW</td></tr> <tr><td>18 (0x12)</td><td>FSTXON</td><td>FSTXON</td></tr> <tr><td>19 (0x13)</td><td>TX</td><td>TX</td></tr> <tr><td>20 (0x14)</td><td>TX_END</td><td>TX</td></tr> <tr><td>21 (0x15)</td><td>RXTX_SWITCH</td><td>RXTX_SETTLING</td></tr> <tr><td>22 (0x16)</td><td>TX_UNDERFLOW</td><td>TX_UNDERFLOW</td></tr> </tbody> </table>	Main Radio Control FSM State			Value	State name	State (Figure 10, page 30)	0 (0x00)	SLEEP	SLEEP	1 (0x01)	IDLE	IDLE	2 (0x02)	XOFF	XOFF	3 (0x03)	VCOON_MC	MANCAL	4 (0x04)	REGON_MC	MANCAL	5 (0x05)	MANCAL	MANCAL	6 (0x06)	VCOON	FS_WAKEUP	7 (0x07)	REGON	FS_WAKEUP	8 (0x08)	STARTCAL	CALIBRATE	9 (0x09)	BWBOOST	SETTLING	10 (0x0A)	FS_LOCK	SETTLING	11 (0x0B)	IFADCON	SETTLING	12 (0x0C)	ENDCAL	CALIBRATE	13 (0x0D)	RX	RX	14 (0x0E)	RX_END	RX	15 (0x0F)	RX_RST	RX	16 (0x10)	TXRX_SWITCH	TXRX_SETTLING	17 (0x11)	RX_OVERFLOW	RX_OVERFLOW	18 (0x12)	FSTXON	FSTXON	19 (0x13)	TX	TX	20 (0x14)	TX_END	TX	21 (0x15)	RXTX_SWITCH	RXTX_SETTLING	22 (0x16)	TX_UNDERFLOW	TX_UNDERFLOW
Main Radio Control FSM State																																																																															
Value	State name	State (Figure 10, page 30)																																																																													
0 (0x00)	SLEEP	SLEEP																																																																													
1 (0x01)	IDLE	IDLE																																																																													
2 (0x02)	XOFF	XOFF																																																																													
3 (0x03)	VCOON_MC	MANCAL																																																																													
4 (0x04)	REGON_MC	MANCAL																																																																													
5 (0x05)	MANCAL	MANCAL																																																																													
6 (0x06)	VCOON	FS_WAKEUP																																																																													
7 (0x07)	REGON	FS_WAKEUP																																																																													
8 (0x08)	STARTCAL	CALIBRATE																																																																													
9 (0x09)	BWBOOST	SETTLING																																																																													
10 (0x0A)	FS_LOCK	SETTLING																																																																													
11 (0x0B)	IFADCON	SETTLING																																																																													
12 (0x0C)	ENDCAL	CALIBRATE																																																																													
13 (0x0D)	RX	RX																																																																													
14 (0x0E)	RX_END	RX																																																																													
15 (0x0F)	RX_RST	RX																																																																													
16 (0x10)	TXRX_SWITCH	TXRX_SETTLING																																																																													
17 (0x11)	RX_OVERFLOW	RX_OVERFLOW																																																																													
18 (0x12)	FSTXON	FSTXON																																																																													
19 (0x13)	TX	TX																																																																													
20 (0x14)	TX_END	TX																																																																													
21 (0x15)	RXTX_SWITCH	RXTX_SETTLING																																																																													
22 (0x16)	TX_UNDERFLOW	TX_UNDERFLOW																																																																													

**0x36 (0xF6): WORTIME1 – High byte of WOR time**

Bit	Field Name	Reset	R/W	Description
7:0	TIME[15:8]		R	High byte of timer value in WOR module

**0x37 (0xF7): WORTIME0 – Low byte of WOR time**

Bit	Field Name	Reset	R/W	Description
7:0	TIME[7:0]		R	Low byte of timer value in WOR module

**0x38 (0xF8): PKTSTATUS – Current GDOx status and packet status**

Bit	Field Name	Reset	R/W	Description
7	CRC_OK		R	The last CRC comparison matched. Cleared when entering/restarting RX mode.
6	CS		R	Carrier sense
5	PQT_REACHED		R	Preamble Quality reached
4	CCA		R	Clear channel assessment
3	SFD		R	Sync word found
2	GDO2		R	Current value on GDO2 pin
1	GDO1		R	Current value on GDO1 pin
0	GDO0		R	Current value on GDO0 pin

**0x39 (0xF9): VCO\_VC\_DAC – Current setting from PLL calibration module**

Bit	Field Name	Reset	R/W	Description
7:0	VCO_VC_DAC[7:0]		R	Status register for test only.

**0x3A (0xFA): TXBYTES – Underflow and number of bytes**

Bit	Field Name	Reset	R/W	Description
7	TXFIFO_UNDERFLOW		R	
6:0	NUM_TXBYTES		R	Number of bytes in TX FIFO

**0x3B (0xFB): RXBYTES – Overflow and number of bytes**

Bit	Field Name	Reset	R/W	Description
7	RXFIFO_OVERFLOW		R	
6:0	NUM_RXBYTES		R	Number of bytes in RX FIFO

### 38 Package Description (QLP 20)

All dimensions are in millimetres, angles in degrees. NOTE: The **CC1100** is available in RoHS lead-free package only.

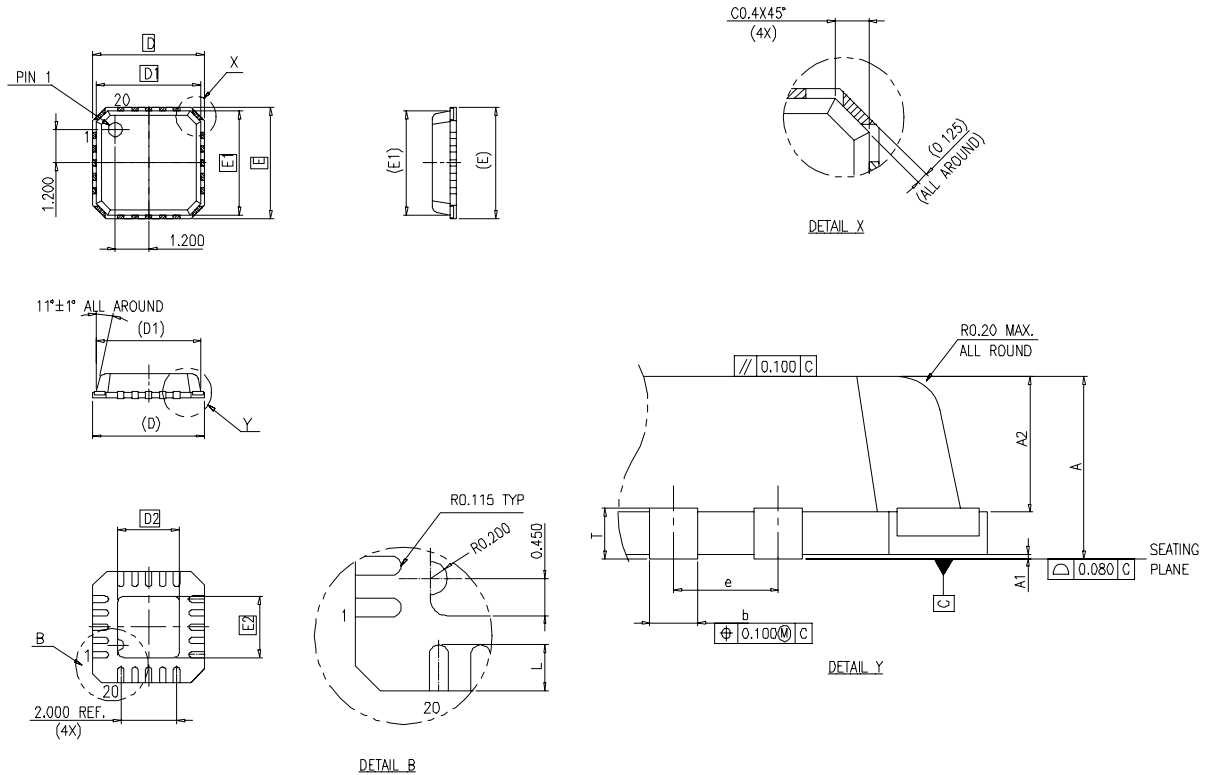
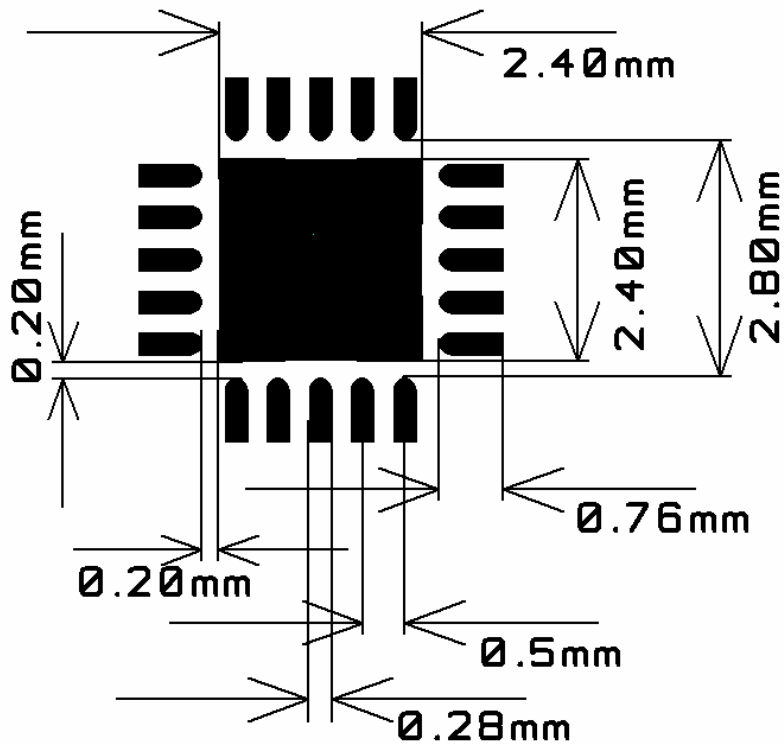

**Figure 17: Package dimensions drawing**

Package type		A	A1	A2	D	D1	D2	E	E1	E2	L	T	b	e
QLP 20 (4x4)	Min	0.75	0.005	0.55	3.90	3.65		3.90	3.65		0.45	0.190	0.18	
	Typ.	0.85	0.025	0.65	4.00	3.75	2.40	4.00	3.75	2.40	0.55		0.23	0.50
	Max	0.95	0.045	0.75	4.10	3.85		4.10	3.85		0.65	0.245	0.30	

**Table 32: Package dimensions**

**38.1 Recommended PCB layout for package (QLP 20)**



**Figure 18: Recommended PCB layout for QLP 20 package**

Note: The figure is an illustration only and not to scale. There are 14 mil diameter via holes distributed symmetrically in the ground pad under the package. See also the CC1100EM reference design.

**38.2 Package thermal properties**

Thermal resistance	
Air velocity [m/s]	0
Rth,j-a [K/W]	TBD

**Table 33: Thermal properties of QLP 20 package**

**38.3 Soldering information**

The recommendations for lead-free reflow in IPC/JEDEC J-STD-020C should be followed.



### 38.4 Tray specification

**CC1100** can be delivered in standard QLP 4x4mm shipping trays.

Tray Specification				
Package	Tray Width	Tray Height	Tray Length	Units per Tray
QLP 20	125.9mm	7.62mm	322.6mm	490

**Table 34: Tray specification**

### 38.5 Carrier tape and reel specification

Carrier tape and reel is in accordance with EIA Specification 481.

Tape and Reel Specification					
Package	Tape Width	Component Pitch	Hole Pitch	Reel Diameter	Units per Reel
QLP 20	TBD	TBD	TBD	13 inches	2500

**Table 35: Carrier tape and reel specification**

## 39 Ordering Information

Ordering part number	Description	Minimum Order Quantity (MOQ)
1166	<b>CC1100</b> - RTY1 QLP20 RoHS Pb-free 490/tray	490 (tray)
1200	<b>CC1100</b> - RTR1 QLP20 RoHS Pb-free 2500/T&R	2500 (tape and reel)
1197	<b>CC1100</b> SK Sample kit 5pcs.	1
1172	<b>CC1100</b> <b>CC1150</b> DK-433MHz Development Kit	1
1173	<b>CC1100</b> <b>CC1150</b> DK-868MHz Development Kit	1

**Table 36: Ordering Information**

## 40 General Information

### 40.1 Document History

Revision	Date	Description/Changes
1.0	2005-04-25	First preliminary Data Sheet release

**Table 37: Document history**

### 40.2 Product Status Definitions

Data Sheet Identification	Product Status	Definition
Advance Information	Planned or Under Development	This data sheet contains the design specifications for product development. Specifications may change in any manner without notice.
Preliminary	Engineering Samples and First Production	This data sheet contains preliminary data, and supplementary data will be published at a later date. Chipcon reserves the right to make changes at any time without notice in order to improve design and supply the best possible product.
No Identification Noted	Full Production	This data sheet contains the final specifications. Chipcon reserves the right to make changes at any time without notice in order to improve design and supply the best possible product.
Obsolete	Not In Production	This data sheet contains specifications on a product that has been discontinued by Chipcon. The data sheet is printed for reference information only.

**Table 38: Product Status Definitions**

### 40.3 Disclaimer

Chipcon AS believes the information contained herein is correct and accurate at the time of this printing. However, Chipcon AS reserves the right to make changes to this product without notice. Chipcon AS does not assume any responsibility for the use of the described product; neither does it convey any license under its patent rights, or the rights of others. The latest updates are available at the Chipcon website or by contacting Chipcon directly.

As far as possible, major changes of product specifications and functionality, will be stated in product specific Errata Notes published at the Chipcon website. Customers are encouraged to sign up to the Developers Newsletter for the most recent updates on products and support tools.

When a product is discontinued this will be done according to Chipcon's procedure for obsolete products as described in Chipcon's Quality Manual. This includes informing about last-time-buy options. The Quality Manual can be downloaded from Chipcon's website.

Compliance with regulations is dependent on complete system performance. It is the customer's responsibility to ensure that the system complies with regulations.

### 40.4 Trademarks

*SmartRF*<sup>®</sup> is a registered trademark of Chipcon AS. *SmartRF*<sup>®</sup> is Chipcon's RF technology platform with RF library cells, modules and design expertise. Based on *SmartRF*<sup>®</sup> technology Chipcon develops standard component RF circuits as well as full custom ASICs based on customer requirements and this technology.

All other trademarks, registered trademarks and product names are the sole property of their respective owners.

### 40.5 Life Support Policy

This Chipcon product is not designed for use in life support appliances, devices, or other systems where malfunction can reasonably be expected to result in significant personal injury to the user, or as a critical component in any life support device or system whose failure to perform can be reasonably expected to cause the failure of the life support device or system, or to affect its safety or effectiveness. Chipcon AS customers using or selling these products for use in such

applications do so at their own risk and agree to fully indemnify Chipcon AS for any damages resulting from any improper use or sale.

## Address Information

Web site: <http://www.chipcon.com>  
E-mail: [wireless@chipcon.com](mailto:wireless@chipcon.com)  
Technical Support Email: [support@chipcon.com](mailto:support@chipcon.com)  
Technical Support Hotline: +47 22 95 85 45

### Headquarters:

Chipcon AS  
Gaustadalléen 21  
NO-0349 Oslo  
NORWAY  
Tel: +47 22 95 85 44  
Fax: +47 22 95 85 46  
E-mail: [wireless@chipcon.com](mailto:wireless@chipcon.com)

### US Offices:

Chipcon Inc., Western US Sales Office  
19925 Stevens Creek Blvd.  
Cupertino, CA 95014-2358  
USA  
Tel: +1 408 973 7845  
Fax: +1 408 973 7257  
Email: [USsales@chipcon.com](mailto:USsales@chipcon.com)

Chipcon Inc., Eastern US Sales Office  
35 Pinehurst Avenue  
Nashua, New Hampshire, 03062  
USA  
Tel: +1 603 888 1326  
Fax: +1 603 888 4239  
Email: [eastUSsales@chipcon.com](mailto:eastUSsales@chipcon.com)

### Sales Office Germany:

Chipcon AS  
Riedberghof 3  
D-74379 Ingersheim  
GERMANY  
Tel: +49 7142 9156815  
Fax: +49 7142 9156818  
Email: [Germanysales@chipcon.com](mailto:Germanysales@chipcon.com)

### Sales Office Asia:

Chipcon AS  
Unit 503, 5/F  
Silvercord Tower 2, 30 Canton Road  
Tsimshatsui, Hong Kong  
Tel: +852 3519 6226  
Fax: +852 3519 6520  
Email: [Asiasales@chipcon.com](mailto:Asiasales@chipcon.com)

### Sales Office Japan:

Chipcon AS  
#403, Bureau Shinagawa  
4-1-6, Konan, Minato-Ku  
Tokyo, Zip 108-0075  
Japan  
Tel: +81 3 5783 1082  
Fax: +81 3 5783 1083  
Email: [Japansales@chipcon.com](mailto:Japansales@chipcon.com)

### Sales Office Korea & South-East Asia:

Chipcon AS  
37F, Asem Tower  
159-1 Samsung-dong, Kangnam-ku  
Seoul 135-798 Korea  
Tel: +82 2 6001 3888  
Fax: +82 2 6001 3711  
Email: [Korea\\_SEAsiasales@chipcon.com](mailto:Korea_SEAsiasales@chipcon.com)

© 2005, Chipcon AS. All rights reserved.